

M01510

59

MERGE 0001

POTTER
Keith

TEC-S/EST-LEA

CERN COURIER

International journal of high energy physics

VOLUME 38

5

SUMMER 1998

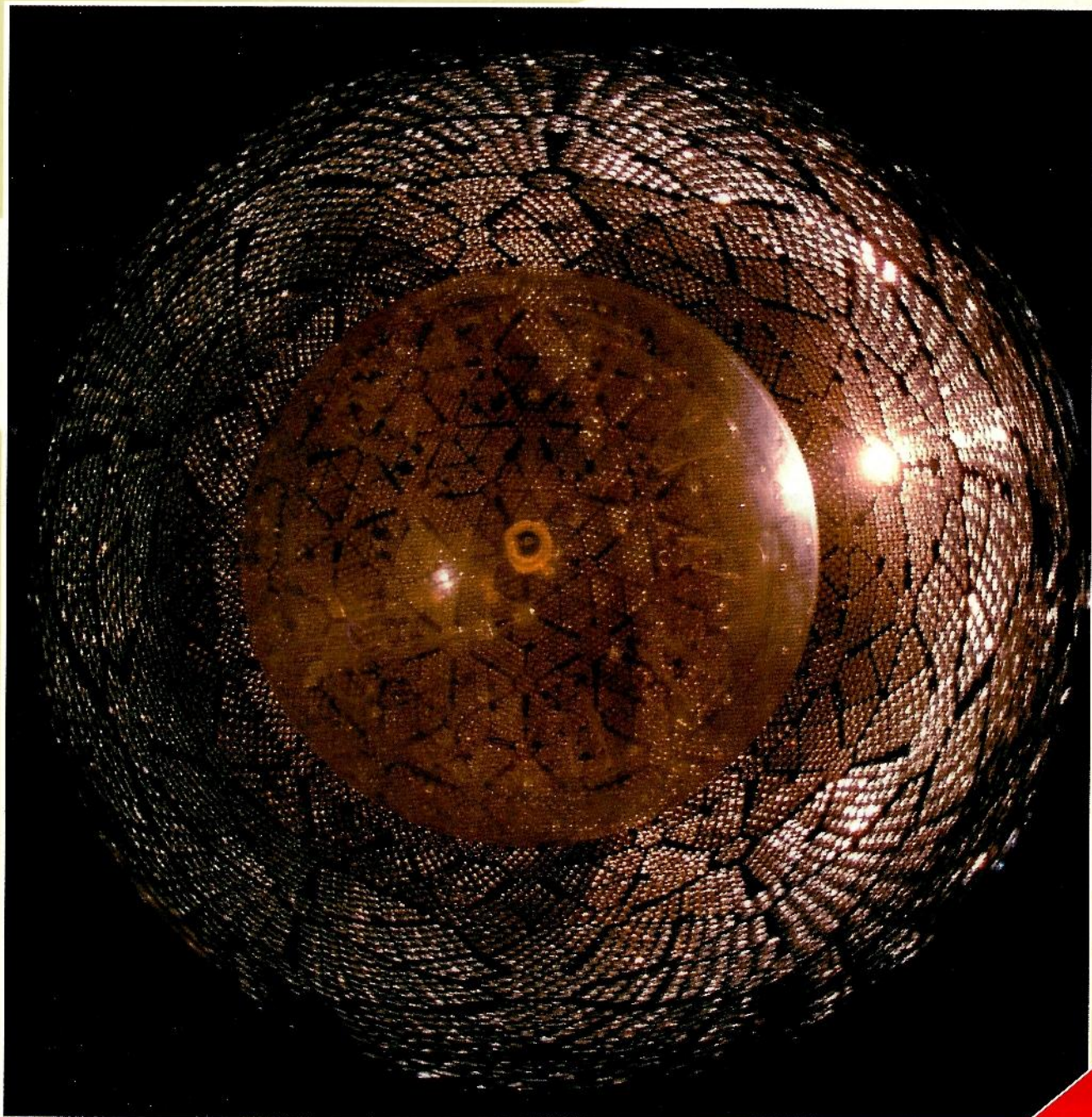

SPECIAL ART ISSUE

21st Century's TDCs

To meet the requirements of the next generation HEP Experiments, two leading European Physics Research Institutes have developed two ASIC

Multihit Time-to-Digital Converters
in VLSI technology.

By integrating them in two single-width, 6U VME modules we have created two modular TDCs featuring an

unprecedented density and the **lowest price per channel** achieved to this date.

They are available now to allow today's experiments to take advantage of **next century's' technology**.

Type*	V667	V673A	V767	V693
Width	1 slot	1 slot	1 slot	1 slot
Channels	64	64	128	128
Bits	21	16	20	16
LSB	780 psec**	1 nsec	780 psec**	1 nsec
DPR	10 nsec	5 nsec	10 nsec	5 nsec
Conv. Time	Nil	Nil	Nil	Nil
Output Buffer	2KWords	4 events 6KWords	32KWords	4 events 12KWords

*VME 6U Units ** 520 psec with speed graded ICs and 60 MHz Clock

The V667 and V767 are based on an IC developed at CERN by the ECP-MIC Group
The V673A and V693 are based on an IC developed for the KLOE experiment by INFN-Roma



UNI EN ISO 9001
CERTIFICATE N° 9105.CAEN



COSTRUZIONI APPARECCHIATURE ELETTRONICHE NUCLEARI S.p.A.

Iscritta all'Albo dei Laboratori di ricerca (Deccr. Min. 25/3/90)

Via Vetraia, 11 - 55049 VIAREGGIO (ITALY) - Tel. (0584) 388398 - Fax (0584) 388959 - E-mail: info@caen.it - URL: http://www.caen.it

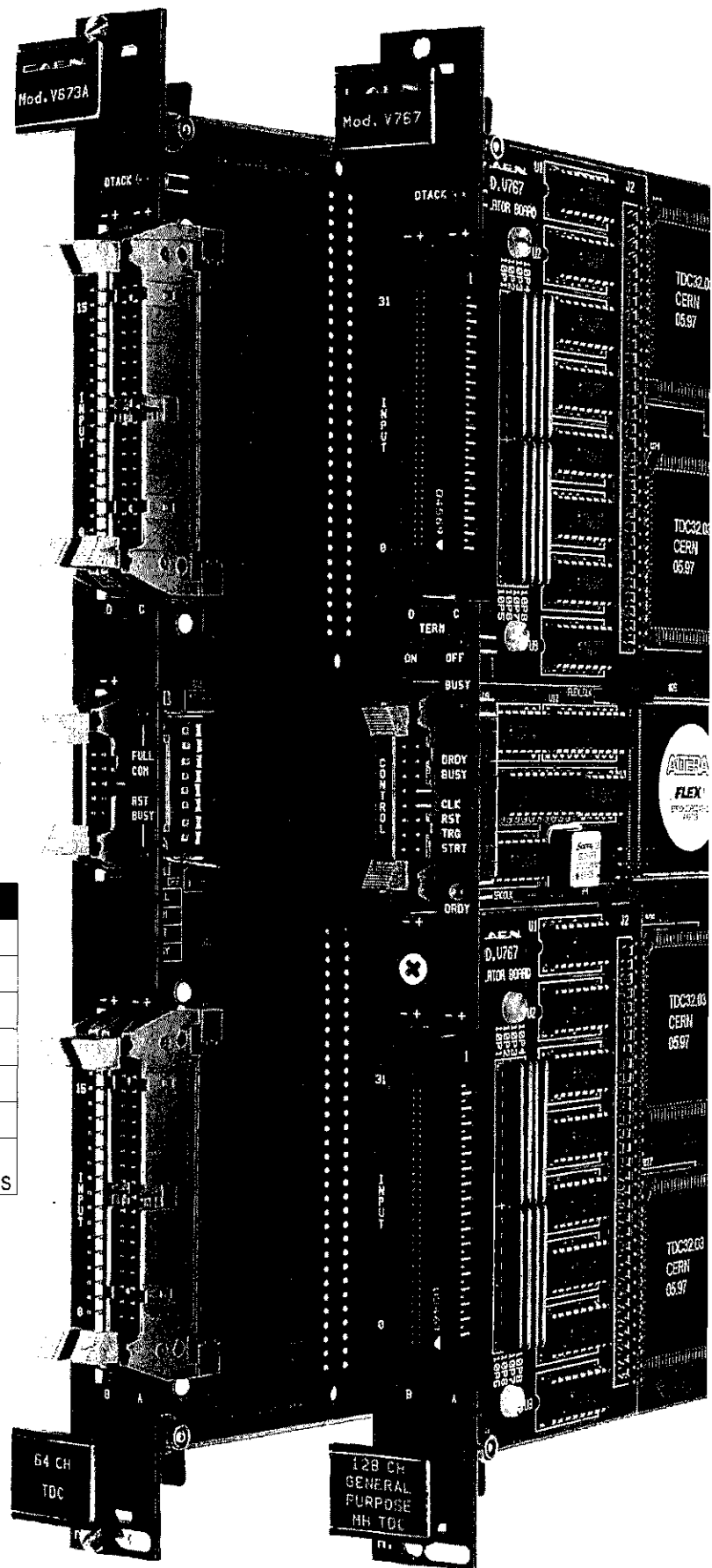

Advertising enquiries

Europe

Micheline Falciola
Advertising Manager
CERN
CH-1211 Geneva 23, Switzerland
Tel.: +41 (22) 767 4103
Fax: +41 (22) 782 1906

Rest of the world

Guy Griffiths
Advertising Manager, USA
International Publishers Distributor
820 Town Center Drive
LANGHORNE PA 19047
Tel.: (215) 750-2642
Fax: (215) 750-6343

Distributed to Member State governments, institutes and laboratories affiliated with CERN, and to their personnel.

General distribution

Jacques Dallemagne
CERN, 1211 Geneva 23, Switzerland

In certain countries, to request copies or to make address changes contact :

China

Chen Huaiwei
Institute of High Energy Physics
P.O. Box 918, Beijing,
People's Republic of China

Germany

Gabriela Heessel or Astrid Nagel
DESY, Notkestr. 85, 22603 Hamburg 52

Italy

Mrs. Pieri or Mrs. Montanari
INFN, Casella Postale 56
00044 Frascati, Roma

United Kingdom

Su Lockley
Rutherford Appleton Laboratory,
Chilton, Didcot, Oxfordshire OX11 0QX

USA/Canada

Janice Voss
Creative Mailing Services
P.O. Box 1147
St. Charles, Illinois 60174
Tel.: 630-377-1589 / Fax: 630-377-1569

CERN COURIER is published monthly except January and August in English and French editions. The views expressed in the Journal are not necessarily those of the CERN management.

Printed by: Drukkerij Lannoo nv
8700 Tielt, Belgium

Published by:

European Laboratory for Particle Physics
CERN, 1211 Geneva 23, Switzerland
tel.: +41 (22) 767 61 11,
telex: 419 000 CERN CH,
telefax: +41 (22) 767 65 55

CERN COURIER only:
tel. +41 (22) 767 41 03,
telefax +41 (22) 782 19 06

USA: Controlled Circulation
Periodicals postage paid at St. Charles,
Illinois

ISSN 0304-288X

Volume 38
No. 5
Summer 1998

Covering current developments in high energy physics and related fields worldwide

Editor: Gordon Fraser
CERN.COURIER@ CERN.CH

Production and Advertisements:
Micheline Falciola
Micheline.Falciola@cern.ch

Advisory Board: E.J.N. Wilson (Chairman), E. Lillestol,
M. Neubert, D. Treille; with L. Foà,
J. Ferguson

World Wide Web <http://www.cern.ch/CERN/Courier/>

Around the Laboratories

- | | |
|----|---|
| 1 | Sudbury - new neutrino observatory |
| 4 | Forward vision at KEK
<i>Japanese laboratory looks to the future</i> |
| 10 | APAC apace
<i>First Asian Particle Accelerator Conference</i> |

14 Bookshelf

15 Special Art Section

Around the Laboratories

- | | |
|----|---|
| 21 | CERN: A special milestone/Physics in space and from space |
| 22 | FERMILAB: 1998 is 1BC
<i>The heaviest meson yet</i> |
| 24 | DESY: State treaty provides legal basis for planning
linear collider |
| 25 | KEK: International workshop on Japan Hadron Facility science |
| 26 | PROTVINO: New channeling records
<i>Crystal-clear beams</i> |

Physics monitor

- | | |
|----|---|
| 28 | Synchrotron light in the Middle East |
| 28 | The unsolved riddle of Ettore Majorana
<i>60 years since the disappearance of a gifted Italian physicist</i> |
| 33 | Particle physics in the Netherlands |
| 38 | People and things |

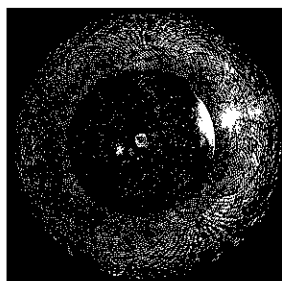

Cover photograph: The Sudbury Neutrino Observatory was recently inaugurated (see page 1). This photo shows the completed SNO acrylic vessel and surrounding photomultiplier tubes and reflectors as viewed from the bottom of the detector. The detector cavity, 34 metres high by 22 metres in diameter, is situated 2000 metres underground in an active nickel mine operated by INCO Ltd near Sudbury, Ontario, Canada, (Courtesy Lawrence Berkeley National Laboratory)

More choice than ever before with new, simple MidiVac.

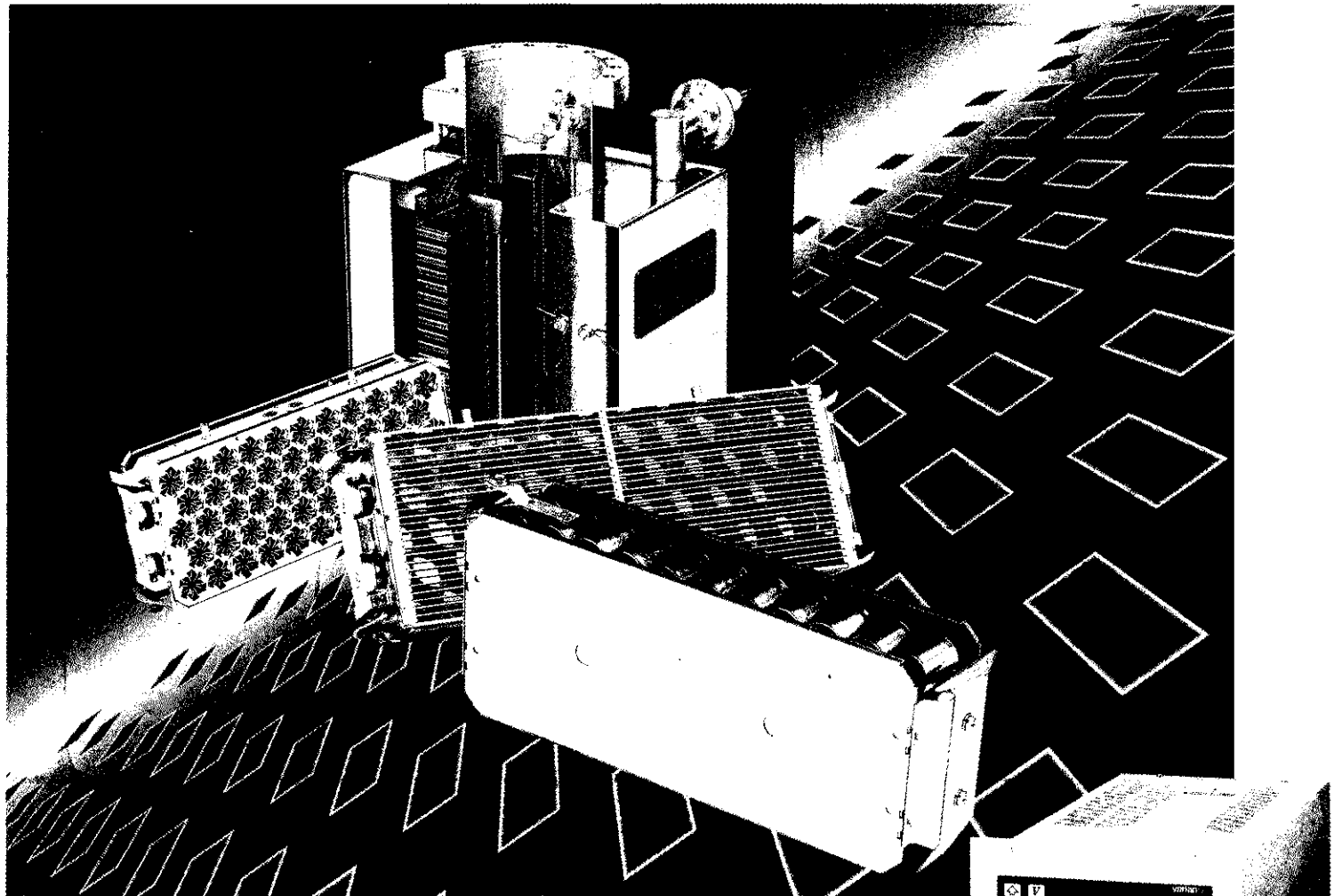

With the addition of MidiVac to our series of ion pump controllers, Varian now offers more choice and flexibility than ever before. Designed to power any size and type of ion pump, MidiVac features single- or dual-voltage outputs for simultaneous control of two ion pumps. With the latest in design features, it can be interfaced with a computer. Yet, it is simple and easy to operate.

Now you can select just the right controller to fit your specific application whether it is the low-cost MiniVac, the ultra-versatile MultiVac, or the new MidiVac.

Varian also offers the broadest range of ion pumps available. With Diode, Noble Diode, and StarCell pumping elements, each Varian VacIon Plus pump is optimized to pump specific gases.

Look to Varian for vacuum made simple. Whatever your pumping needs, our VacIon pumps and controllers offer a complete solution. For more information, see us at <http://www.varian.com>, or call us at:

1-800--8VARIAN in the U.S.
39.11.9979111 (Italy) in Europe
81.3.52321253 in Japan



varian 

Sudbury - new neutrino observatory

Participants in the opening ceremonies for the Sudbury Neutrino Observatory in Canada, left to right: SNO Project Director Art McDonald of Queens University; John Bahcall, of Princeton's Institute For Advanced Study; 1994 Physics Nobel Laureate Bert Brockhouse of McMaster; Stephen Hawking of Cambridge and 1990 Physics Nobel Laureate Richard Taylor of Stanford. The new Observatory will soon become a major player on the world neutrino stage.

The Sudbury Neutrino Observatory, officially opened on 29 April, will soon become a major player on the world neutrino stage. With neutrino physics difficult to carry out, and reliable results even harder to obtain, the availability of such a large detector promises to bring this fuzzy area of physics into sharper focus.

The official opening ceremony marked the completion of eight years of construction and the start of detector operation. The ceremonies were attended by SNO scientists and governmental representatives from Canada, the US and the UK as well as members of the international scientific community, including Nobel laureates Bert Brockhouse and Richard Taylor, neutrino astrophysicist John Bahcall, Gran Sasso Laboratory Director Alessandro Bettini and cosmologist Stephen Hawking.

The conceptual design of the SNO project was begun in 1984, following a proposal by Herb Chen of UC Irvine, for the use of heavy water for solar neutrino detection. Herb Chen, who passed away in 1987, was one of the original co-spokesmen, along with George Ewan of Queen's University, Kingston, Canada. Last year a memorial to Chen was unveiled at the new laboratory.

The SNO scientific collaboration includes about 100 scientists from 11 institutions in Canada, the US and the UK. The \$74 million capital construction cost has been shared by funding agencies in the three countries and construction has been underway since 1990 with Art McDonald of Queen's University as Project Director.

The central feature of the SNO Cerenkov detector is the use of 1000 tonnes of heavy water to detect



neutrinos from the sun and supernovae. The \$300 million-worth of heavy water is on loan for \$1 from the Canadian government agency AECL. The detector cavity, 34 metres high by 22 metres in diameter, is situated 2000 metres underground in an active nickel mine operated by INCO Ltd near Sudbury, Ontario, Canada.

The heavy water, contained in a 12 metre diameter, 6 cm thick acrylic vessel, is viewed by 9500 phototubes mounted on an 18 metre diameter concentric geodesic sphere. The 20 cm diameter phototubes are augmented by light concentrators which provide an overall geometrical light collection efficiency of about 70%.

The detector cavity, lined with a thick polyurethane water and radon barrier, is filled with 7000 tonnes of ultra-pure light water as a radioactive shield. At this depth, cosmic ray background is negligible.

The detector has been designed and constructed to maintain the lowest possible levels of background. All detector materials have been carefully selected or specially produced for minimum radioactivity. The construction was entirely carried out with Class 3000 clean room conditions, with all workers showering and changing clothes after the trip through the mine to the site. Water purification and monitoring systems are capable of maintaining uranium and thorium content at

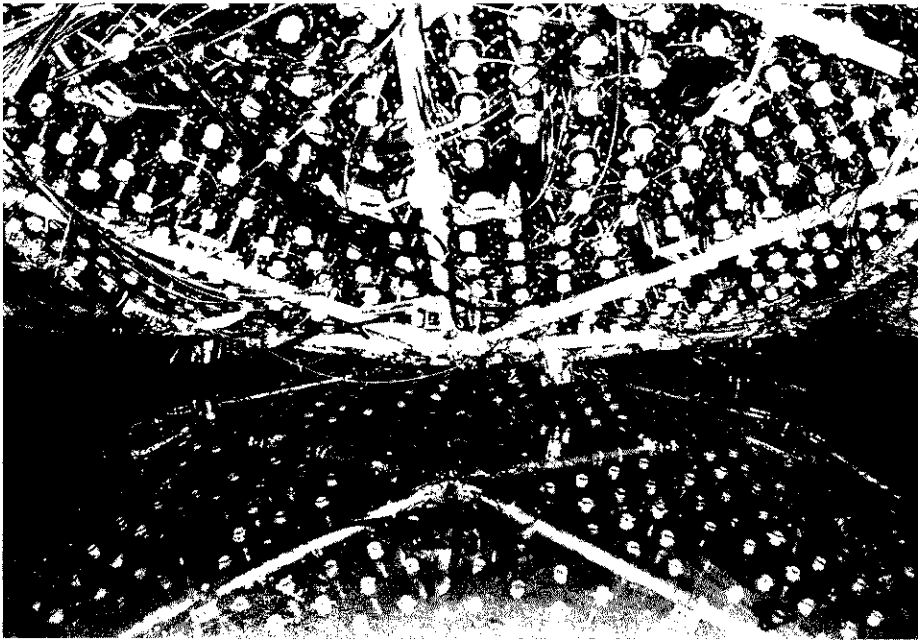

The bottom of the SNO detector cavity, showing the outside of the geodesic sphere and photomultiplier tube panels, reflected also in the surface of the water as it filled the cavity (the photo was taken end-April).

Neutrino mass

Latest data from the 50,000 tonne Superkamiokande underground detector in Japan suggests that muon-type neutrinos 'oscillate', changing into other neutrino types. This is only possible if the neutrinos have mass, opening the door to a lot of physics. Neutrinos, from the decays of particles produced as cosmic rays hit the atmosphere, arrive in the detector from all directions. For more than ten years, such experiments have seen fewer muon neutrinos than expected. The deficit is particularly marked for upward-travelling neutrinos (which have passed through the Earth before hitting the detector, and have more chance of being transformed. An effect already seen in Superkamiokande's initial data (September 1997, page 25) is now confirmed. The news was announced at Neutrino 98 in Takayama, Japan, early in June. A major report follows in the next issue.

levels less than 10^{-14} for both the heavy and the light water in the region inside the light detectors.

All individual parts of the detector had to be less than about 2.5 by 3 by 4 metres in order to be transported in the mine hoist. As result, the acrylic sphere was fabricated from about 130 separate parts, bonded together in situ with liquid acrylic. Of the 1 km of bonds completed, only about 5 metres required remedial work to remove imperfections. The application of repair techniques to individual bond sites was very complex and time consuming, resulting in significant time extensions for the project. The acrylic vessel, completed last December, has been found to exceed all engineering requirements.

The use of heavy water provides unique scientific advantages for the detection of solar and supernova neutrinos. There are two observable reactions with deuterium. The first (charged current) reaction, specific to electron neutrinos, involves the inverse beta decay of the neutron, producing a slow proton and an electron with an energy nearly equal to the incoming neutrino energy. This reaction will be detectable above a neutrino energy of 6.4 MeV through the Cerenkov light produced by the electron.

A second reaction (this time neutral current) is equally sensitive to all

neutrino types and involves the neutrino disintegration of deuterium providing a free neutron which is thermalized in the heavy water. The threshold for this reaction is 2.2 MeV, so both reactions are sensitive only to neutrinos from beryllium-8 decay in the sun, with very small contributions possible from other neutrinos.

Several techniques will be employed to detect the neutron, providing an independent measure of all neutrino types.

This results could reveal the reason for the dearth of solar electron neutrinos observed by other experiments - the long-standing 'solar neutrino problem'. The deficit could be due to neutrino oscillations - electron neutrinos leaving the sun changing into other neutrino types en route (see box).

Comparison of the charged and neutral current reaction rates provides an indication of electron neutrinos changing to other, non-sterile, neutrinos, independent of normalization by solar model calculations. In addition, the measurements provide a measure of the original solar neutrino flux for comparison with solar models. This combination of measurements could provide a clear answer to the origin of the solar neutrino problem.

The reaction rates for both the charged and neutral current reaction

lead to estimates of over 2500 counts per year for each reaction, providing good statistical accuracy.

The detector will also be sensitive to neutrino elastic scattering from electrons, with a counting rate of about 300 per year and good directional sensitivity.

The neutrons will be detected by two techniques. In one, 0.2% (two tonnes!) of magnesium chloride is dissolved in the heavy water so that the neutrons are mainly captured in chlorine, producing 8.5 MeV of gamma energy which is detected through the Cerenkov process. Techniques have been developed for the introduction and removal of the salt over a few week period.

The second technique involves the installation of about 120 helium-3-filled proportional counters to provide a clear neutron detection signal

CES PRESENTS:

Two major building blocks for the next generation of DAQs

A general-purpose detector read-out card

- Detector input
 - 128-bit wide
 - 100 Mbytes/s
- On-board Computing Kernel
 - PowerPC 603ev or Arthur133 MHz to 200 MHz
 - 16 or 64 Mbytes SDRAM
 - 2 Mbytes Flash EPROM
- CES Optimized PowerPC / PCI bridge
 - Independent chained DMA channels
 - 120 message passing mechanism
- Comprehensive set of software tools and services

MFCC 8441

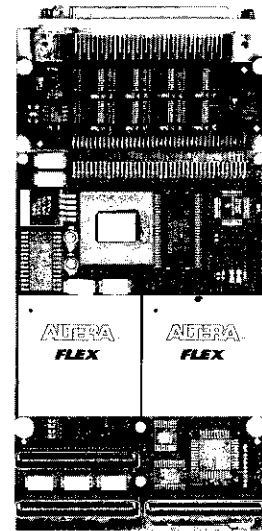

Up to 6 MFCC 8441 can be attached to a single RIO2 8062 processor.

PVIC 8425

A transparent PCI to PCI link at full PCI speed

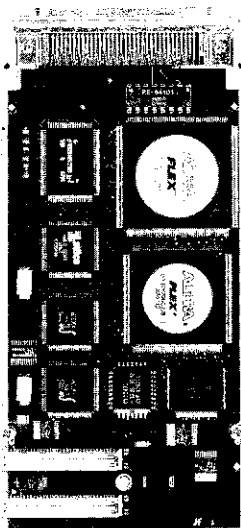

- Fully transparent byte, word, long-word transactions
- Full PCI-speed traffic at 132 Mbytes/s bandwidth
- Support for interprocessor communication
- Hardware test and set mechanism
- Advanced interrupt dispatching logic for remote and local interrupt handling
- On-board autonomous block mover offering chained DMAs executed concurrently with the transparent mode
- Unique set of advanced broadcast modes
- Libraries and drivers optimized for real-time (Lynx-OS, VxWorks)
- Comprehensive set of software libraries

With the PVIC 8425 any number of MFCC 8441 can be interconnected at full PCI speed.



Your Real-Time Partner



For any additional information about this product or our complete PowerPC, PMC, Connections, VME, CAMAC and FASTBUS line, do not hesitate to contact us.

CES Geneva, Switzerland Tel: +41-22 792 57 45 Fax: +41-22 792 57 48 EMail: ces@ces.ch
CES.D Germany Tel: +49-60 55 4023 Fax: +49-60 55 82 210
CES Creative Electronic Systems SA, 70 Route du Pont-Butin, CH-1213 Petit-Lancy 1, Switzerland
Internet: <http://www.ces.ch>

CES
CREATIVE ELECTRONIC SYSTEMS

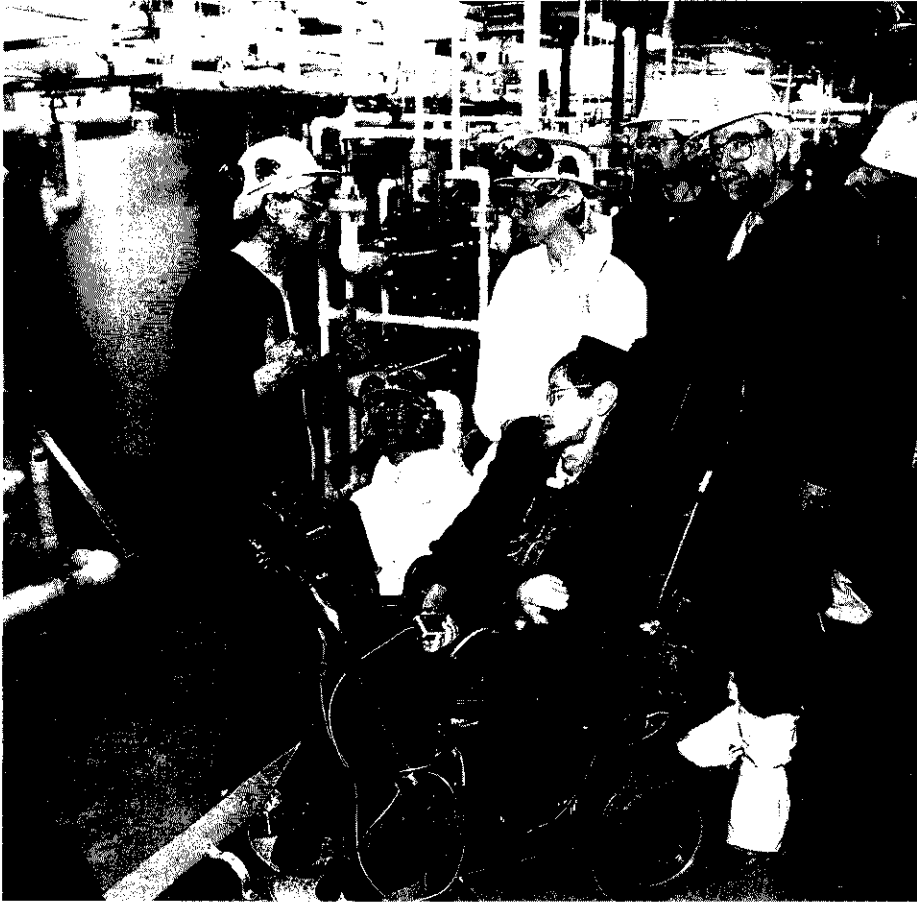

VIP guest Stephen Hawking, with SNO Associate Director David Sinclair (left) and Director Art McDonald (right), during a visit to the underground laboratory

together with position information. The 6 cm diameter counters are made from ultra-pure nickel produced via chemical vapour deposition, resulting in extremely low radioactive background.

The most important background to be controlled in the experiment is that of gamma rays with energy greater than 2.2 MeV, which are capable of photodisintegrating deuterium to

create a neutron as background for the neutral current reaction. The only significant source of such gammas is expected to be the thorium and uranium decay chains and the extraordinary measures for the control of radioactivity are primarily aimed at these elements and their daughters, including radon. With the measures being taken it is expected that the background for the neutral

current reaction will be controlled and measured to be well below the level of the neutral current reaction. In this case, the ratio of the reactions and the resulting evidence for change in neutrino flavour will be observable with excellent systematic as well as statistical accuracy.

In the event of a supernova, the SNO detector will have excellent sensitivity to muon and tau neutrinos through the neutral current reaction. Good sensitivity is provided for the measurement of neutrino mass through the comparison of the time profile of electron neutrino and antineutrino events and those from the neutral current reaction. During the next three months the SNO scientists will be taking data as the detector fills with water, providing differential measurements of the radioactive background from the parts of the detector. At the end of that period, neutrino observations will begin.

From Art McDonald, Queen's University, SNO Project Director

Forward vision at KEK

In April, we published the first of a series of 'forward vision' articles on major world laboratories. The continual push for innovation and fresh goals in particle physics, so vital to healthy research, shows no signs of abating. This month we look at the Japanese KEK Laboratory, which has grown from a modest national research centre to a major player on both the national and the world stages.

KEK, formerly the Japanese National Laboratory for High Energy Physics, was established in 1971 in Tsukuba Science City around a 12 GeV proton synchrotron. In the last 27 years, the laboratory has developed into one of the world research centres with a variety of accelerator facilities, including both proton and electron machines serving material and life sciences as well as particle and nuclear physics.

Reflecting this development, in a major reorganization last year KEK, now renamed the High Energy Accelerator Research Organization, incorporated two related institutions of the University of Tokyo, the Institute of Nuclear Study (established in 1955) and Meson Science Laboratory (established in 1980). The new KEK is currently attracting 3400 visitors annually from 24 countries.

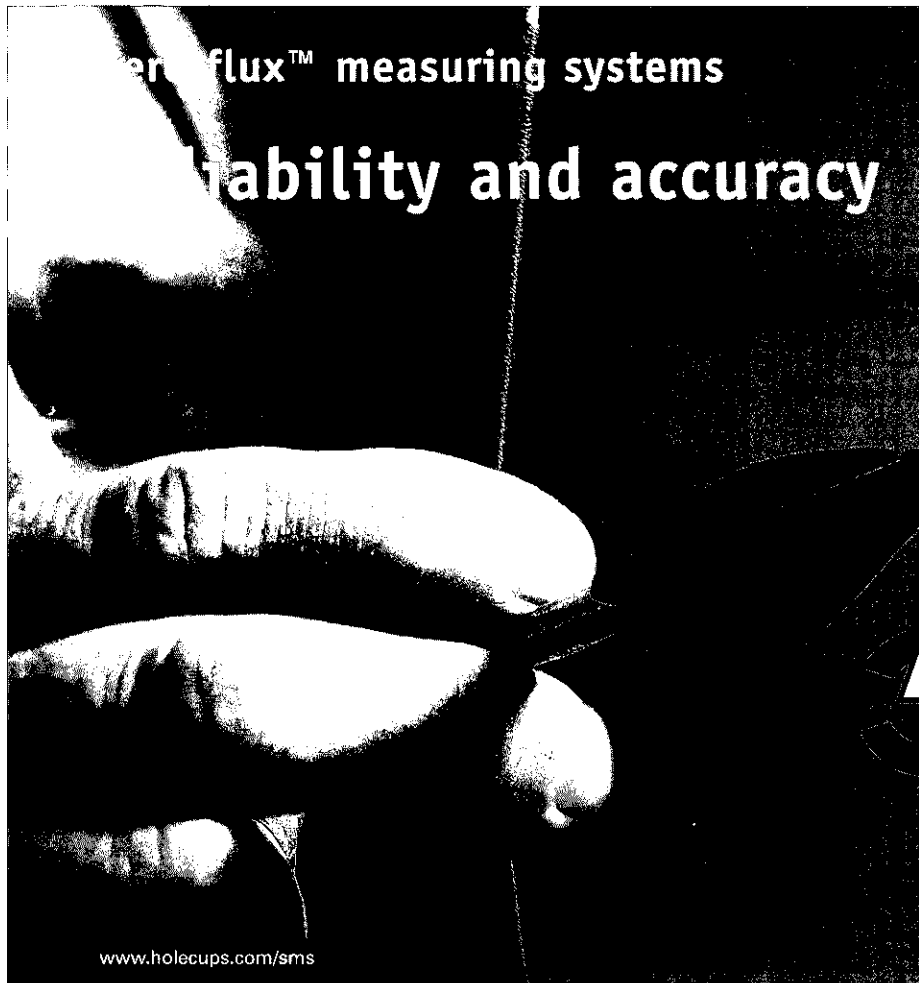

Zero-flux™ measuring systems

Stability and accuracy

www.holecups.com/sms

SPECIAL MEASURING SYSTEMS

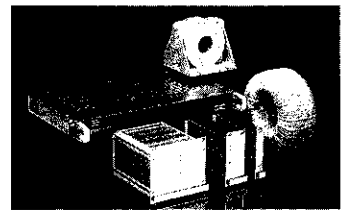

Sometimes a good eye and a steady hand are all you need. However, for measuring currents with high accuracy and reliability you need other qualities. You need a Zero-flux™.



HOLEC
Power Protection

P.O. Box 4
7550 GA Hengelo
The Netherlands
Phone: +31 74 246 28 53
Fax: +31 74 246 26 78
e-mail: sales_sms@compuserve.com

UNE HAUTE IDÉE DE L'ENTREPRISE

À 10 minutes de l'aéroport international de Genève, au carrefour des réseaux autoroutiers F/CH/D/I, près de deux gares TGV, à proximité du prestigieux CERN.

*propose sur 40 hectares :
des parcelles de terrains viabilisées (achat ou location)
des bureaux et des bâtiments mixtes
une pépinière d'entreprises
des services spécifiques d'assistance aux entreprises pour une implantation régionale et pour des relations avec le CERN
un Bureau de Rapprochement des Entreprises agréé par l'UE.*

LE TECHNOPARC - PAYS DE GEX -

A Ten minutes' drive to Geneva International Airport, at the crossroads of the F/CH/D/I motorways, close to two TGV railway stations, right next to the prestigious CERN.

*proposes 100 acres (40 ha) of equipped site with :
pieces of land (purchasing or renting)
offices spaces
activity buildings
incubator
Business Corporation Center agreed by EU.*

CONTACT :
COMMUNAUTÉ DE COMMUNES DU PAYS DE GEX
Technoparc - Pays de Gex -
F-01630 Saint-Genis-Pouilly
Tél. 04 50 42 65 00 - Fax 04 50 42 65 01
E-mail : bregex@leman.com
internet : <http://www.leman.com/~bregex>

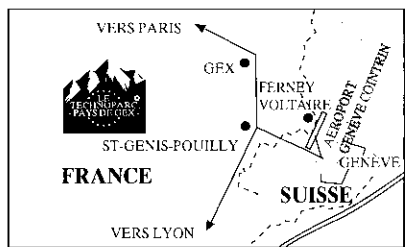

At the Japanese KEK Laboratory, construction of the KEKB asymmetric-energy two-ring collider is nearing completion in the tunnel originally built for the TRISTAN electron-positron collider. The two KEKB rings are installed side-by-side in the tunnel. The smaller magnets (right) are for the positron ring and the larger ones for the electron ring.



On the electron machine side, construction of an asymmetric-energy two-ring collider, KEKB, is nearing completion. This is a conversion of the TRISTAN electron-positron collider (1986-95) fully utilizing its infrastructure and is scheduled to begin commissioning this autumn. 3.5 GeV positrons and 8 GeV electrons stored in separate rings will circulate in opposite directions and collide at one interaction point in Tsukuba experimental hall. The TRISTAN tunnel is large enough to accommodate the two rings side by side.

The injector linac has been upgraded from 2.5 GeV to 8 GeV to facilitate direct injection of electrons and positrons and increase the positron intensity by increasing the energy of electrons on a positron production target.

KEKB aims at a luminosity of 10^{34} per sq cm per s by squeezing the high current electron (1.1 A) and positron (2.6 A) beams to 77 microns horizontally and 1.9 microns vertically

The Belle detector at the KEKB interaction point, with the connection box of a focusing quadrupole visible. The detector can be moved in and out for installation and careful tuning with beam

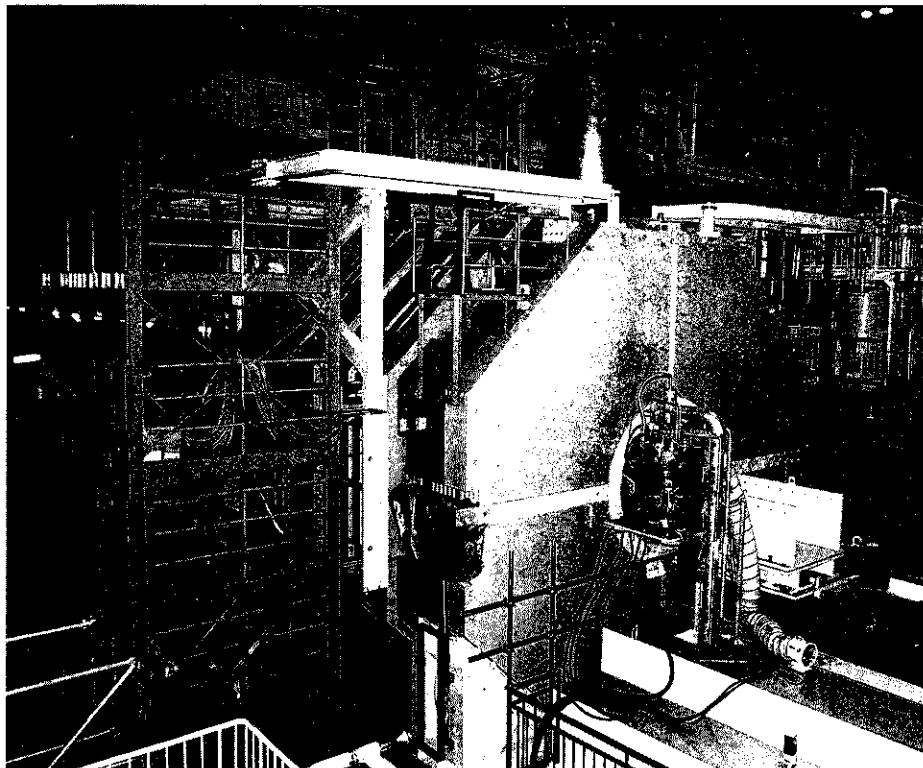

at the interaction point. Normal conducting cavities (ARES) and single-cell, single-mode superconducting cavities are used to handle these large currents.

One feature of KEKB is finite-angle crossing at the interaction point. Beams collide at ± 11 mrad horizontally. This useful scheme eliminates the use of separation dipole magnets that would produce strong synchrotron light close to the interaction points where a silicon vertex detector is located.

The BELLE detector is installed at the KEKB interaction point in Tsukuba experimental hall. The BELLE collaboration includes about 300 researchers from 11 countries. Their detector is a versatile solenoid spectrometer for electron-positron collisions, arranged slightly asymmetric along the beam direction, corresponding to the asymmetric collisions.

The barrel of the detector has a silicon vertex detector (SVD), a drift chamber (CDC), an aerogel cherenkov counter (ACC), time-of-

flight counters (TOF), a cesium iodide crystal calorimeter (ECL), a 1.5 T solenoid and a kaon and muon detector. The forward (electron direction) endcap is equipped with an aerogel detector and a CsI calorimeter while the backward one has only a CsI calorimeter.

The main physics goals are the observation of CP violation in B-meson decays, the precise determination of the (Kobayashi-Maskawa) matrix elements describing the various quark processes and the rare decays of B-mesons.

The predicted B physics CP violation will emerge when data samples reach an integrated luminosity of 100 inverse femtobarns - corresponding to one year of running at the design luminosity.

Detector construction began in 1994. Most sub-detectors have been built and are being integrated into the iron yoke structure. Assembly will be complete by the end of the year, and the whole detector will move into the collision point after

Aerial photograph of the KEK neutrino beamline construction taken in March. A primary beamline tunnel, emerging from an experimental hall (bottom left), is bent by about 90 degrees towards the direction of the SuperKamiokande detector, 250 kilometres away. A target hall and a decay tunnel are seen under construction. Beyond the decay tunnel can be seen a hole which will accommodate the near neutrino detector. Its kiloton water Cherenkov tank is waiting at the top left corner.



first commissioning of the beam this autumn.

The KEKB injection linac will also provide positron or electron beam to the 2.5 GeV and 6.5 GeV storage rings dedicated to synchrotron radiation research. The former, in use since 1982, was upgraded in 1997 to improve its emittance (from 130 to 27 nmrad) by doubling the number of quadrupole and sextupole magnets between bending magnets and by several other measures. With this improvement, the brilliance of the synchrotron radiation sources is expected to be enhanced by a factor of 5 to 10.

The 2.5 GeV ring supplies synchrotron light to 61 experimental stations, including some dedicated to industrial and Australian institutes. The 6.5 GeV ring was formerly the TRISTAN accumulator ring and was converted to a dedicated single bunch X-ray source suitable for

studies of transition phenomena in materials. It is currently providing six experimental stations with hard x-rays.

On the proton side, the original 12 GeV proton synchrotron is still playing an important role in particle and nuclear physics. As a precious source of kaons, this machine is used for CP and T violation experiments as well as various studies of nuclear effects including hypernuclei and chiral (left-right) symmetry restoration. In addition, this machine is being widely used to develop particle detectors for future experiments such as those at CERN's LHC and at the Japan Linear Collider, JLC.

A large effort is currently underway for a long baseline neutrino oscillation experiment, the first neutrino experiment in the 20-year history of the KEK proton machine. Known as K2K (KEK to

Kamioka) and scheduled to begin operations next January, it is the world's first long-baseline neutrino oscillation search based on an accelerator. Motivated by the atmospheric-neutrino anomaly observed by Kamiokande and SuperKamiokande (September 1997, page 25), this experiment aims at an investigation of neutrino mass and mixing in the region of favoured by the data.

A precise measurement of the neutrino flux, energy spectrum, and contamination at the production site is important. This uses a near detector consisting of a mini-kamiokande detector of 1 kiloton of water, a scintillating-fibre (SCIFI) tracker interleaved with water target layers, lead-glass counters, and a muon range telescope.

A new beamline and an underground experimental hall for the near detector are under construction in the KEK site. The neutrino beam, with an average energy of 1.4 GeV, will be directed at the Super Kamiokande detector in the Kamioka mine 250 km west of KEK, operated by the University of Tokyo Institute for Cosmic Ray Research.

The PS 500 MeV booster synchrotron is providing 80% of its proton beam to neutron scattering, meson science and medical therapy facilities. The Neutron Science Laboratory produces spallation neutrons with two moderators, circulating water at ambient temperature and solid methane at 20 K, for thermal and cold neutrons, respectively. These are used, together with 17 spectrometers, by in-house and visiting scientists for fundamental physics as well as studies of crystal structure and excitations of materials including liquids and glasses.

The KEK synchrotron radiation facilities, showing plan views of the 2.5 GeV ring (bottom) and the 6.5 GeV ring (top right).

PF 2.5 GeV Ring and Beam Lines

PF-AR (6.5 GeV) Beam Lines

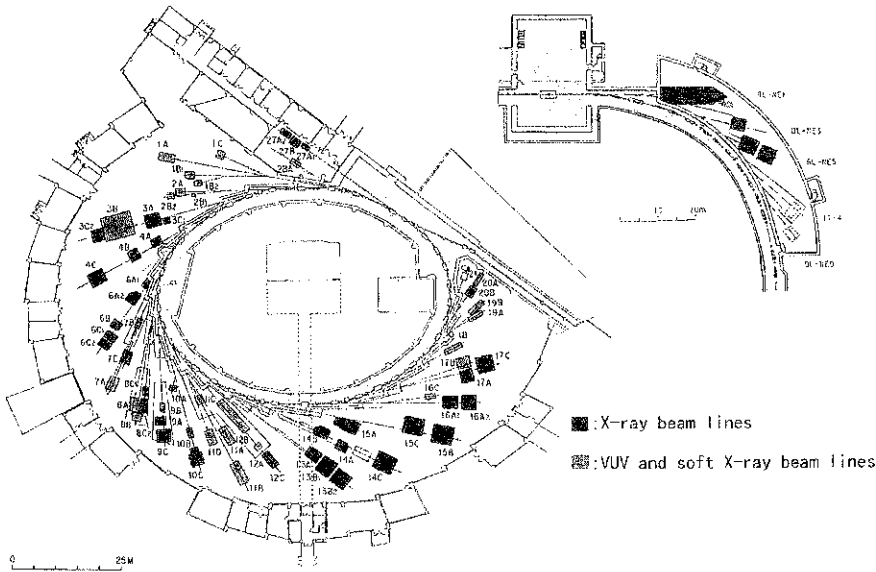

The Meson Science Laboratory uses three sharply pulsed (50 ns wide and 20 Hz) muon beams - a 100 MeV positive or negative muon beam, a 4 MeV positive muon beam and an ultra-slow 10 keV positive muon beam, used for condensed matter studies.

The Medical Research Facility is operated by the University of Tsukuba and has successfully treated 571 cancer patients. Building on this experience, the University of Tsukuba is constructing its own dedicated proton therapy machine on campus.

These world pioneering facilities, built around 1980, have produced remarkable results and excellent research. However, after about 20 years, demand has developed for powerful new facilities, and a new project for a hadron accelerator complex was proposed by researchers from many different disciplines. The JHF (Japan Hadron Facility) consists of a 200 MeV proton linac, a 3 GeV 200 microamp booster ring,

and a 50 GeV 10 microamp main synchrotron ring. It aims at promoting further activities over a broad field of science, extending from nuclear and particle physics to material and life sciences.

At the 50 GeV proton synchrotron, secondary beams of kaons, antiprotons, pions, and hyperons, as well as primary protons and heavy ions will be available for experiments. The nuclear physics programmes range from strangeness physics to hadron spectroscopy with antiprotons. Particle physics ranges from rare kaon and muon decays to neutrino oscillation.

The 3 GeV Booster ring would provide a high-power 0.6 MW beam and will be used for three major experimental programmes - a spallation neutron source, high-intensity muon beams for material science and biology, and on-line isotope-type radioactive beams for nuclear physics.

When the JHF is complete, it should be open to the entire international

science community, where support and enthusiasm for the project are growing.

To complement their existing facilities and short-term projects, particle physicists at KEK and from universities in Japan have placed a linear electron-positron collider machine (JLC) on the top of their list of future projects and strongly support R&D at KEK towards such an ambitious machine.

The machine study has made remarkable progress, so that an actual design is near at hand. The importance of the project has been further reinforced recently by the Subcommittee on Future Projects of High Energy Physics in Japan.

The major focus of current R&D at KEK is the prototype injector complex (Accelerator Test Facility, ATF) and the high-power radiofrequency technology for main linacs. The ATF has been constructed to investigate the feasibility of all the techniques related to producing multibunch beams with unprecedentedly low emittance. A 1.54 GeV injector linac has already been routinely operated at the impressive accelerating gradient of 30 MV/m. A 1.54 GeV damping ring was commissioned early in 1997 and has been under intensive study in collaboration with many institutes, both in Japan and overseas. The beam quality already exceeds the measuring capabilities of readily available devices. An extensive, single-shot beam-monitor system is being improved and the beam-based alignment technique is showing its worth. Accelerator specialists are confident that the design performance will be achieved in about a year.

The main linacs will have to accelerate the beams over long distances without impairing the input beam

High-Tech Superconductors produced by
a world leading industrial Group

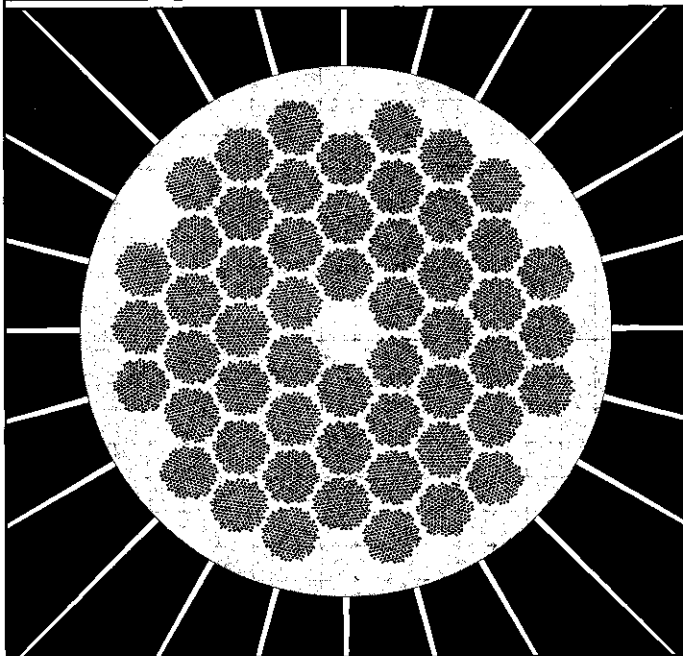

LARGE SCALE PRODUCTION OF:

- Nb/Ti and Nb₃Sn wires
- Rutherford cables
- Coextruded Al stabilized cables
- C/C with Al alloy and stainless steel jackets
- High temperature superconductors



EUROPA METALLI spa
SUPERCONDUCTORS DIVISION

55052 FORNACI DI BARGA (Lucca) - Italy
Phone + 39 (583) 701422 - 701447
Fax + 39 (583) 75007

www.metrolab.com

Global range of
magnetic measurement
equipments

METROLAB
Instruments SA

- NMR
- ESR
- Hall effect
- Digital fluxmeter
- from mT to 50 Tesla
- Accuracy
10⁻² to 10⁻⁸

tel : +41 (22) 884 33 11
fax : +41 (22) 884 33 10
E-mail: contact@metrolab.ch
110, ch. du Pont-du-Centenaire
CH-1228 GENEVA Switzerland

www.metrolab.com

Une gamme
complette

d'appareils de mesure
pour l'industrie

Dans le monde entier, les capteurs Endress+Hauser permettent le contrôle et le pilotage de process industriels variés, notamment dans les domaines de la chimie, de l'agro-alimentaire et du traitement de l'eau.

Précision et fiabilité sont les qualités reconnues des appareils de mesure Endress+Hauser.

niveau

débit

pression

analyse

température

humidité

enregistreurs

auto-surveillance

communication

services

Endress+Hauser AG
Sternenhofstrasse 21
CH-4153 Reinach BL 1
Telefon 061 - 715 62 22 ■ Fax 061 - 711 16 50
E-mail : info@ch.endress.com
<http://www.endress.com>

Endress+Hauser

Le savoir-faire et l'expérience



APAC

apace -

first Asian Particle Accelerator Conference

quality. They consist of a large number of accelerator units, each unit being a combination of RF power sources (klystrons), a power distribution system and accelerating structures.

A series of prototype tests and the latest simulation study indicate good prospects for a rapid payoff in powerful klystrons. New schemes have been developed for efficient RF power distribution. High-precision machining and fabrication techniques for the accelerating structure have been considerably improved in recent years. Prototypes can sustain a high enough acceleration field and, at the same time, minimize adverse effects of wake fields from beam bunches. Improved versions will soon be tested with beam. All these developments in main-linac technology have the mass-production phase in mind.

In addition to these activities in Japan, collaboration with overseas laboratories is one of the pillars of

KEK research. This includes the US/ Japan collaboration programme in particle and nuclear physics experiments, as well as the development of accelerator technologies, the UK/ Japan programme in neutron research, and collaborations in Europe represented by ATLAS/LHC and HERA.

With this ambitious and wide-ranging programme, KEK is a major player in world physics, with facilities in Japan attracting many scientists from overseas, while Japanese specialists have major roles in important projects, particularly in the US and in Europe..

The Japan Hadron Facility (JHF) project. The tunnels for the 200 MeV linac and 50 GeV main ring are to be excavated respectively near the existing 12 GeV tunnel and inside the KEKB tunnel while the 3 GeV booster ring is to be built in the present 12 GeV PS tunnel. Other infrastructure of the 12 GeV PS is also fully utilized. The main ring will also supply a 50 GeV proton beam to the neutrino line under construction for the K2K experiment.

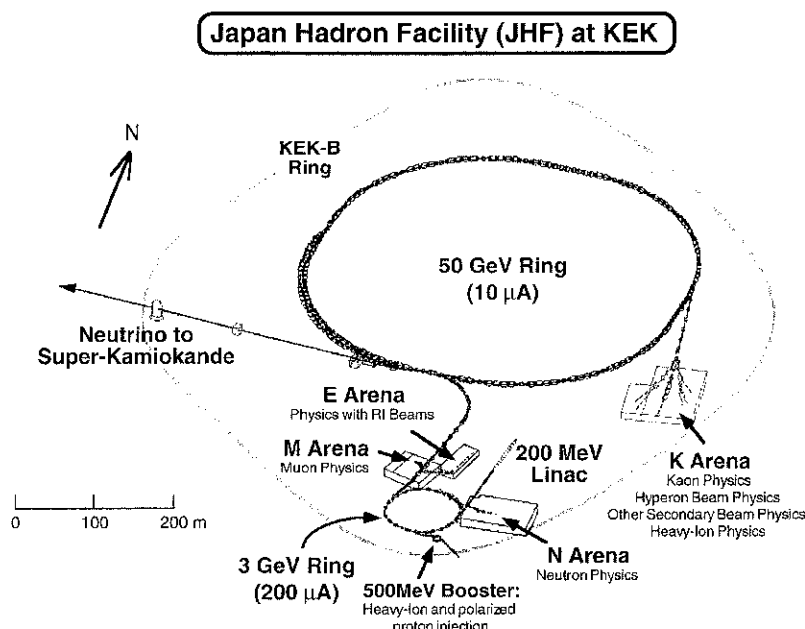

It was a milestone event in the history of Asian accelerator science when four hundred specialists from all over Asia assembled at the Japanese KEK laboratory in Tsukuba from 23 - 27 March for the First Asian Particle Accelerator Conference - APAC98.

Although it was the first such conference, accelerator science and technology is not new in Asia. Low energy accelerators - high-voltage generators, electron linear accelerators and cyclotrons - have been quite common in many countries. However the profile of the Asian accelerator community has greatly changed since the 1980s, when synchrotron radiation achieved popularity.

Providing very bright sources from ultra-violet to x-rays, synchrotron radiation has attracted scientists in many fields - physics, chemistry, biology, and medicine. Many light sources have been constructed and more are still being planned in Asia.

Responding to this interest, the Asian Committee for Future Accelerators (ACFA) was formed in April 1996. Reflecting the rapid growth in accelerator-based science in Asia, ACFA's stated objective is to promote mutual understanding of activities, and to strengthen international collaboration among Asian countries.

The first meeting of ACFA was held in Pohang, Korea, home of the Pohang Light Source. At the meeting, ACFA decided to hold a regular Asian Particle Accelerator Conference (APAC), the first venue being Tsukuba.

In his APAC98 opening address, H. Sugawara, chairman of ACFA and Director-General of KEK, explained the motivation of ACFA and its role, and stressed the importance of close

Four hundred accelerator scientists from all over Asia participated in the first Asian Particle Accelerator Conference, held at the Japanese KEK laboratory.



collaboration among Asian countries in the field of accelerator science.

In individual country reports presented on the first day of the conference, representatives gave an overview on the activity in their respective nations. The speakers were Shuxian Fang (China), S. S. Kapoor (India), A. Djaloelis (Indonesia), M. Inoue (Japan), Won Namkung (Korea), Swee-Ping Chia (Malaysia), Richard Sah (Taiwan), Weerapong Pairuswan (Thailand) and Van-Do Nguyen (Vietnam). An invited talk from Novosibirsk was given by I. Chatounov in place of A. N. Skrinsky.

The area of high energy physics included the activities of the Beijing Electron-Positron Collider (BEPC) and the KEK B-factory. Shin-ichi Kurokawa, reporting on KEKB, impressed his audience by declaring "It is now in the final stage of construction and the commissioning starts this autumn."

Among the next generation high energy accelerator concepts, linear colliders are the most serious contenders, producing head-on collisions of energetic electron and positron beams supplied by very long linear accelerators. A linear

accelerator of the order of 20 kilometres is technically very challenging, and R&D has been pushed for many years at major world high energy accelerator laboratories. At the conference, status reports were presented by KEK, SLAC (Stanford), DESY (Hamburg), and BINP (Novosibirsk/Protvino).

Asian interest in high intensity proton accelerators has developed for various reasons - the production of high intensity neutrons for basic materials research as well as the development of advanced nuclear power technologies for nuclear waste transmutation and power production.

These objectives require proton accelerators with enormous beam power, more than ten times that of the most powerful accelerator in existence. At the conference, three proposals were presented; the Neutron Science Project (NSP) by the Japan Atomic Energy Research Institute (JAERI), the Japan Hadron Facility (JHF) by KEK, and the Korean Multipurpose Accelerator Complex (KOMAC) by Korean Atomic Energy Research Institute (KAERI).

All are multipurpose machines and are very challenging in terms of their

Chitlada Settakorn from Thailand, currently studying at Stanford, reports on work on infrared radiation from sub-picosecond electron bunches.



accelerator technology. C.K. Park of KAERI declared "The KOMAC is a nuclear green project." Both NSP and KOMAC designs incorporate a superconducting linear accelerator of energy around 1 GeV, a very novel technology. The technical innovation for these high-intensity accelerators attracts accelerator scientists and engineers.

Cyclotrons are the accelerators with longest history. Since the invention of the technique in 1931, innumerable cyclotrons have been constructed, first for nuclear physics, and more recently for medical applications.

A noticeable cyclotron advance is the construction of radioactive ion (RI) beam factories. Their beams of unstable nuclei are useful not only for nuclear physics but also for materials science and even for medical applications.

In Asia, two RI beam facilities are already operating - at the Institute of Modern Physics in China and at RIKEN in Japan. Welcome news at the meeting came from Y. Yano of RIKEN, who announced that a new

UNUSUAL

REQUESTS

Goodfellow is an established specialist supplier of small quantities of metals & materials for research, development, prototyping and design.

Our product range is renowned for being the most comprehensive of any source in the world.

Whilst we can't guarantee to make fairy tales come true, we can help with your unusual requests for materials. Contact us now for a copy of our new product guide and find out what we can do for you.

Goodfellow

Goodfellow Cambridge Limited
Cambridge Science Park, Cambridge CB4 4DJ
Great Britain
Telephone: +44 (0)1223 568 068
Fax: +44 (0)1223 420 639
E-mail: info@goodfellow.com
Web: www.goodfellow.com



M1/98

SEIS Omni Ray

Industrial Computer Systems



First PowerPC 750 processor board on VME64 stays cool at high speeds.

MVME2700-Serie

- PowerPC 750 233/266 MHz
- 16-256 MB DRAM
- SCSI / Ethernet / 4xRS232 / Centronics / Floppy/Mouse / Keyboard / PMC-Slot / PCI-Expansion
- AIX, pSOS, LynxOS, OS-9 / OS-9000, VRTX32 and VxWorks, Operating Systems and Kernel Support.

Omni Ray AG, Im Schossacher 12, 8600 Dübendorf
Tel. 01 802 28 80, Fax 01 802 28 28, www.omniray.ch

Omni Ray
The Power of Automation

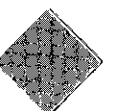

At the conference banquet, V. Balakin from the Russian Budker Institute for Nuclear Physics, Protvino, hands a suitably-sized bottle of vodka to conference chairman Motohiro Kihara of KEK.



RIKEN RIB Factory had been approved by the funding agency. According to the plan, two ring cyclotrons will be constructed to boost the radioactive beam energy from the existing facility. When constructed, it will be the most powerful such factory in the world. As mentioned earlier, synchrotron radiation and free electron lasers are a major focus of attention. Many light sources exist in Asia: counting only user facilities, there are two in China, one in India, three in Japan, one in Korea, and one in Taiwan. The Siam Photon project in Thailand has

already been approved, and Hongjie Xu from the Shanghai Synchrotron Radiation Facility Project reported that they had completed their R&D programme and were awaiting final approval.

In view of their importance to the Asian accelerator community, low- or medium-energy accelerators and their applications figured prominently at APAC. One major application area is the medical sector, for cancer therapy and isotope production. Radiotherapy with electron linear accelerators has been widely used for many years. Recently, proton or heavy-ion therapy has been developed, and several such facilities constructed at Japanese hospitals. Plans for such facilities have also been drawn up in China, Korea and Taiwan.

Material microanalysis is another classic application. An interesting development is for environmental monitoring, where accelerator mass spectrometry has been widely applied for the detection of extremely small amounts of trace elements. Yuzeng Lin from the Tsinghua University of China reported on a

very compact electron linear accelerator with a very high microwave frequency, developed for baggage inspection at airports.

Besides the invited talks, the conference programme included 24 oral and 200 poster presentations. At KEK, participants were able to inspect the construction site of the B factory, the upgraded electron linear accelerator, the Accelerator Test Facility (ATF) for the development of linear collider technology, and the test stand for the JHF linear accelerator.

The conference was an exciting event for younger participants in particular, and was judged a major success.

On March 25, the third meeting of ACFA, held in parallel, elected Zhipeng Zheng of IHEP (China) and Won Namkung of POSTECH (Korea) as next chairman and vice-chairman, respectively. The second APAC is provisionally scheduled to be in China in 2001. The conference closed with an address by the ACFA chairman-designate and a symbolic handshake between the present chairman and his successor.



The chairman's baton of the Asian Committee for Future Accelerators (ACFA) was handed from Hiroataka Sugawara (left) of KEK, Japan, to Zhipeng Zheng of IHEP, China.

Bookshelf

Particle Astrophysics by H V Klapdor-Kleingrothaus and K Zuber:
Institute of Physics Publishing ISBN
0 7503 0403 0

This new book is more than just a graduate level textbook, as its title suggests, it is also a sign of the times. Particle astrophysics is a new field emerging as the questions traditionally in the domain of particle physics merge with those of astrophysics. Beginning with a summary of particle physics' Standard Model and Grand Unified Theories, the book moves on to the essentials of cosmology and nucleosynthesis.

Having covered the essential groundwork from both fields, it is the second half of the book in which the overlap between them comes to the fore. Chapters covering subjects from solar neutrinos to axions carefully describe the complementarity of the accelerator approach with observations using passive detectors, both terrestrial and space borne.

The book has been translated into English from the original German (Teilchenphysik ohne Beschleuniger, B G Teubner GmbH, Stuttgart) by S. M. Foster and B. Foster. Publication in the two languages was simultaneous, so the English version is right up to date. In the solar neutrino chapter, for example, preliminary Superkamiokande results from 1997 appear along with descriptions of experiments, such as BOREXINO and SNO, yet to begin.

'Particle Astrophysics' covers a vast range of material and consequently does not delve too deeply into any one subject. Nevertheless, it provides a highly readable account of this new field, and a comprehensive bibliography should satisfy any desire for

further reading. It is a textbook which will be of interest not only to graduate students of the new discipline, but also to established hands in either of its parent fields.

James Gillies

Books received

Confinement, Duality, and Nonperturbative Aspects of QCD, Edited by Pierre van Baal, NATO Advanced Study Institute Series, Plenum Press (New York) \$155 0 306 45826 8

The proceedings (550 pages) of a 1997 NATO Advanced Study Institute school at the Newton Institute for Mathematical Sciences, Cambridge, UK, organized by David Olive, Pierre van Baal, and Peter West, which focused on the ever-topical question of understanding how quarks are confined in subnuclear particles.

Quantum Chance and Non-Locality - Probability and Non-Locality in the Interpretations of Quantum Mechanics, by W. Michael Dickson, Cambridge University Press 0 521 58127 3

Ever since its introduction in the 1920s, the underlying logic of quantum mechanics has been difficult and opaque. This book looks at the description of the various interpretations of quantum mechanics, in particular their implications for probability and non-locality.

Mathematical Topics in Fluid Mechanics, Volume 2 Compressible Models by Pierre-Louis Lions Oxford Science Publications 0 19 8514883 39 £39.50 hbk

In the Oxford Lecture Series in Mathematics and its Applications, this is a companion volume to Volume 1, on Incompressible Models, by the same author.

9.06.98 - 28.06.98

CERN

Laboratoire européen de physique des particules
Interventions d'art contemporain sur le site de Meyrin
Vernissage le 9 juin à 17h Main building (60)
Accès libre avec pièce d'identité
Ouvert tous les jours de 14h à 19h

ESAV/DIP Genève, avec le soutien du fond cantonal de décoration

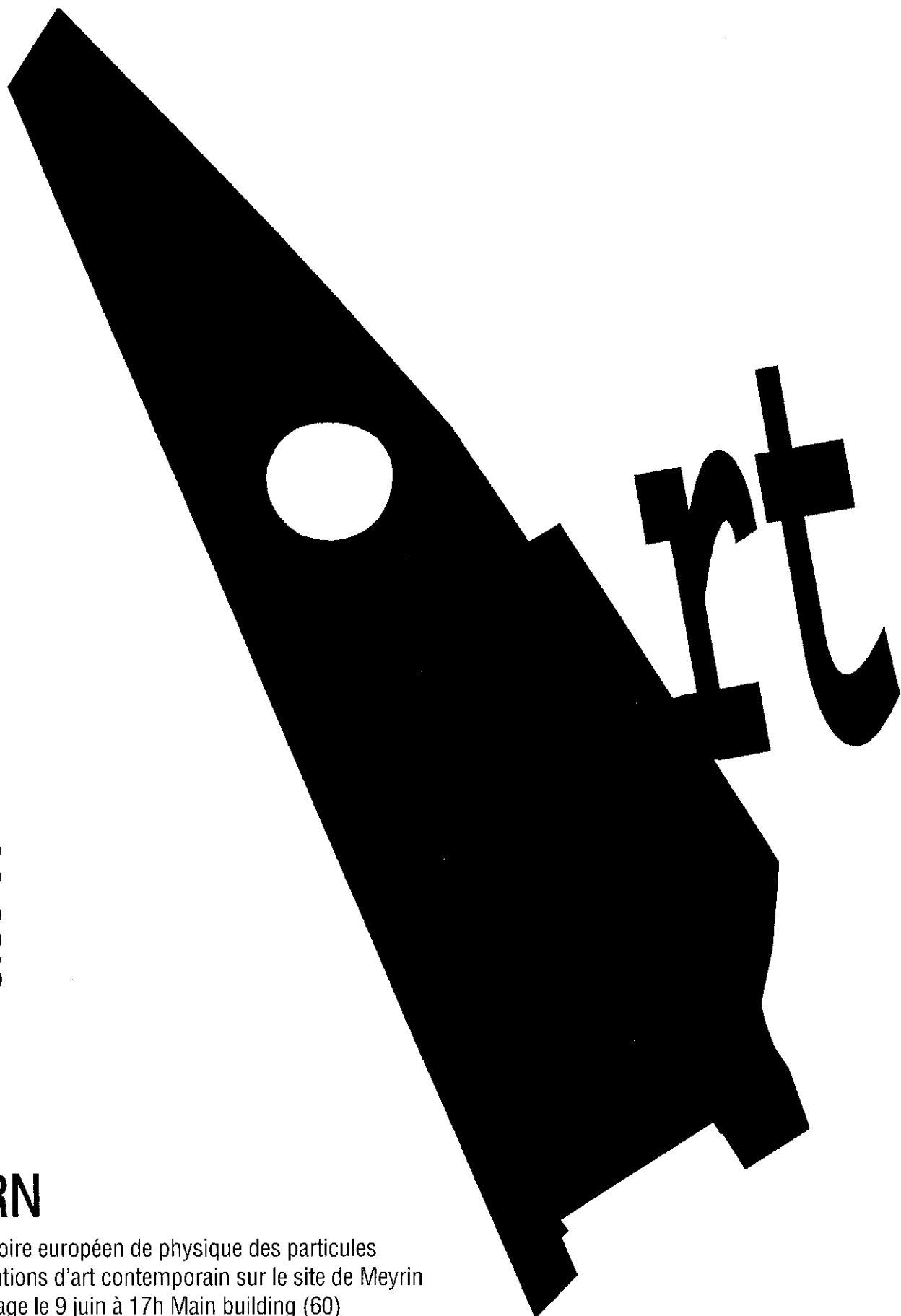

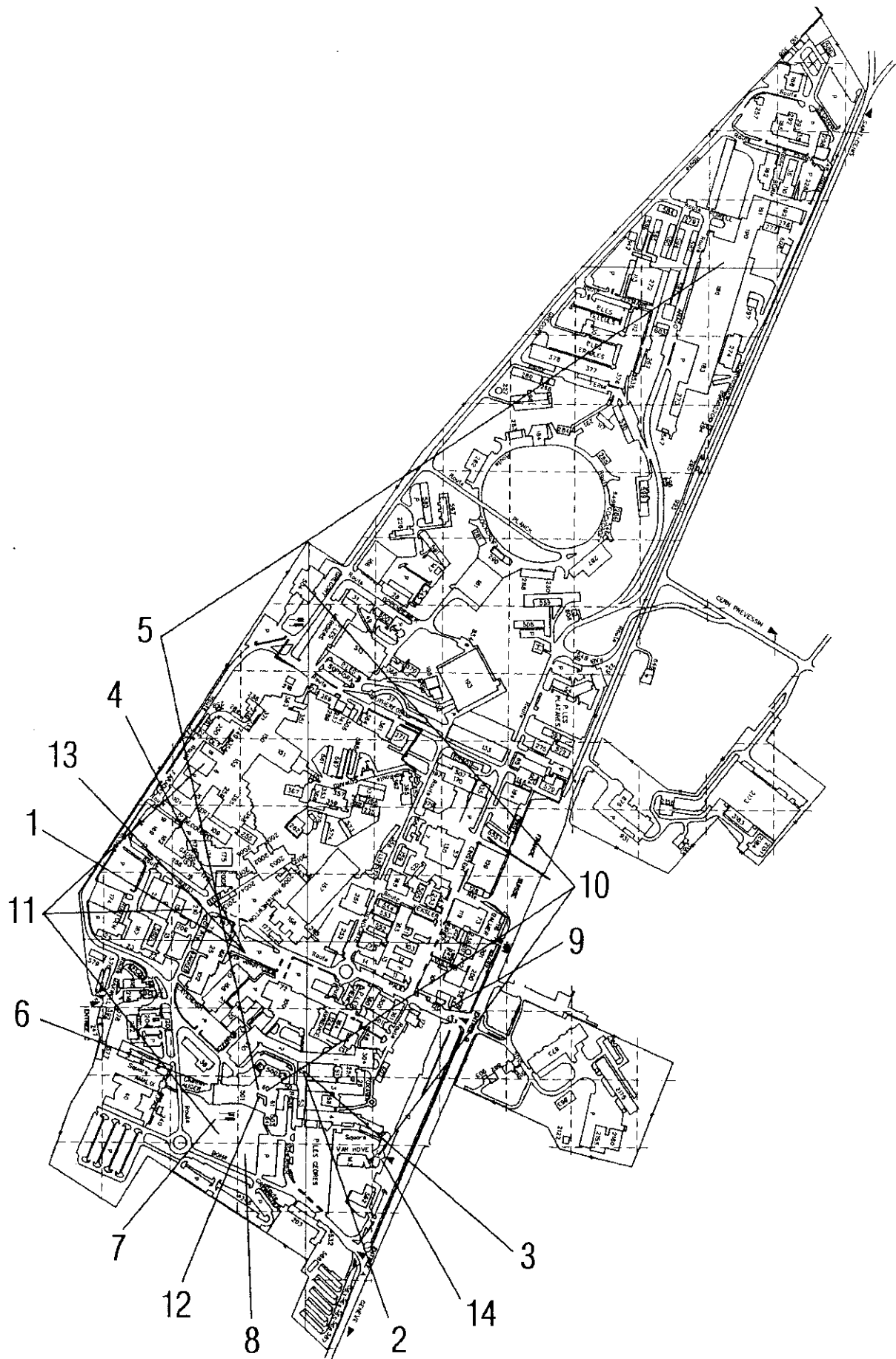

The Uncertainty Principle

(or how one academic year goes too quickly.....)

Two teachers at Geneva's Ecole Supérieure d'Art Visuel set out to work on the CERN site during the 1997-8 academic year with a group of second, third and fourth year students. This enabled the students to attempt artistic experiences outside the specific domain of art with the objective of improving their knowledge and experience, the level of their research and their vision of the world in a context which could be described as a truly different environment. The CERN site is an environment of its own with a population made up of different nationalities, professions, cultures and social backgrounds.

This issue of the CERN Courier is interspersed with different artistic contributions, in the form of an image, a text (not always translatable), a drawing or a montage which uses directly the shape and form of its setting. We asked each student to imagine this graphic idea as a symbol of their studies at CERN.

The few months of interaction with users and staff at CERN allowed us to gradually build up small encounters and valuable collaborations to catalyse an understanding of the architectural and social aspects of the site and its landscape.

Viewed from the outside by the visual arts students who worked on the site this year, as well as their teachers, CERN provides not only a novel insight into the world of the extremely small, but also the surprise of a disconcerting strangeness.

Setting up an art studio inside this hybrid and multilayered community and beginning work required the rapid establishment of some reliable (if precarious) benchmarks.

This transplantation to a transnational environment changed our ways of working, requiring us to have more self-solidarity to establish



the confidence and the stimulation to meet the inhabitants and the workplaces of a particle factory.

This unusual context would just have been an end in itself if it had not allowed the students to develop an analysis and conceptualization directed towards the development of novel ideas. This art, by its relevance or otherwise, can surprise both its creator and the public.

We asked the students to study and glean the methods, materials, symbols and lifestyles of CERN to propose a different view of the site, which determines itself as neither true, nor false, nor as a homogeneous viewpoint. Discovery can lead in its own way to comedy or drama.

Each work tries to incorporate a vision of this through the creator's own malleable 'language', a tool which the students look to maintain between themselves and the world around them and whose shape and form show a way of observing this other world, while less expensive, less precise and just as unpredictable as that which CERN's physicists and engineers built with

their accelerators, detectors and superconductors.

One example brings alive the numbered buildings which do not appear on maps, another proposes a LEP relic for archaeologists of the future, while another sows a seasonal path for strollers. Others exploit clothing, maps or the layout of the site and propose an alternative geometry and space.

Other people at CERN were invited to learn to draw, to rediscover souvenirs of their childhood, or to participate in the development of an interactive infographic project. Finally, some everyday objects were adapted to question their accepted banality which for those who have experienced CERN remain a blatant symbol of unforgiving science.

To consolidate and extend the possibilities for encounters between contemporary artistic and scientific visions, we extended our stay at CERN by an exhibition of 14 artistic themes in assorted places, inside and outside. This was open to the public from 10 - 28 June.

Our curiosity was stimulated by the

'TIDE-EYE'
 JE NE SAIS PAS SI NOUS SOMMES SUR
 UN BATEAU TROUE OU S'IL Y A UN TROU
 DANS LA MER!

EDGARD SOARES

"uncertainty principle" that describes how "Z" particles appear in an almost total vacuum, where collisions between electrons and positrons take place at near the speed of light in which they borrow the energy they need.

In the same way we encouraged the students to keep a progressive record of their investigations using the energy of a site that covers one thousand three hundred and eighty three acres and includes many thousand inhabitants.

Carmen Perrin and Jean Stern



1 Sergio Brandao Frazao

"Passage objects": Coloured plastic straws fastened to the ceiling in the sieve of the cafeteria hall. Building N° 500 has an installation of various objects glued on a table found opposite Building N° 72 and 100. Assembling everyday objects modifies two passage zones.

2 Carola Bürgi

Porcelain ring-shapes displayed in a line in one of the library's study rooms. This sculpture recalls an imaginary archaeology on the site. It is related to texts contained in books nearby.

3 Pascal Cavin

Release of 414 snails on 4 June on Route Cockroft. They signal and account for the number of missing buildings on the site.

An artist's book documenting architecture and snails will be available at the library's entrance.

4 Elodie Formaris (ECAL, Lausanne)

Interactive infography and sound work presented in barrack 6590 on the Route Newton car park. The barrack contains three detectors that delimit equivalent zones between the far end of the room and a video monitor. On the screen one can see images in motion that change shape when the detector signals movement. The Silicon Graphics System is loaned by ECAL, Lausanne.

5 Pierre-Philippe Freymond

Three installations:
 - To the right of the cafeteria kiosk and on the first floor, a display of various graphic elements, photographs and objects question the surroundings in connection with notions of the natural and the artificial.
 - Building 180, "zootrope", a circular box containing animated images.
 - Postcards available at the CERN kiosks and reception.

6 Aline Guillet

A structure of steel blocks outside the south-west corner of building 501. This sculpture reacts to the materials, proportions and external architectural elements of the cafeteria's main façade.

An artist's book is also available at the entrance of the library. It contains a written and photographic account of the artist's first circuit on the site.

7 Claudia Gisler

Outside the site, opposite the main cafeteria's terrace, the architecture of a projection room is similar to the temporary laboratories used for particle physics experiments. It consists of blocks of concrete with a steel roof. Inside this room runs a video installation that contains among other things a collection of childhood dreams told by CERN staff. They are related to those of Claudia Gisler. The video material is loaned by the ESAV in Geneva.

Je chemine, tu chemines, il chemine, nous cheminons, vous cheminez, ils cheminent.

MARIA RAMPINI

8 Julien Israelian

A tent on the lawn facing main cafeteria's terrace. Inside it there is an assembling made of work garments used on the site, wooden shelves and stretchers. Clothes become objects and furniture becomes sculpture. The tent is loaned by CERN.

9 Sladjan Nedeljkovic

In the reception hall and in those of the cafeterias, stand display shelves entitled "Privilege". Inside them are numerous copies of a map of the site. The maps are available for the public. These folded sheets bear a graphic work on both sides. They invent a new topography for the site.

10 Marina Rampini

"Weaving". White threads woven in a group of trees on the corner of Routes Pauli and Bakker as well as two trees opposite the cafeteria's terrace. The taut surfaces provide geometric plans that mark a path, orientate a zone of circulation and set the limits of a visual hindrance in relation to the landscape

11 Edgard Soares

In the pool by the cafeteria float eighty tyre tubes that have been slightly modified to make a series of smaller pools. The other part of the installation is made of various "diverted" objects that create sort of a sculptural choreography in which elements are actuated by small



motors or by the shocks caused by random contact with one another.

12 Julie Wälti

Inside barrack 6740 on Route Newton car park is an installation consisting of a series of documents that recount a search about the landscape above the LEP tunnel. This archive also explains an event that has already taken place. The student has planted red poppy seeds on this path. Within two years one will be able to see and follow a 27 kilometre circular line of poppies.

13 Cristina Wirth

On a low table in the reception's hall stands a video monitor with earphones. Seated in an armchair one can switch on the film and watch a group drawing lesson with the 'Etch a Sketch' game. This work questions

the learning and control of drawing under the appearance of an aerobics workout. This work is completed outside the building by the presence of flags whose image was conceived after drawings made by CERN users invited to: "Draw the CERN flag for me please."

14 Myriam Nattier

In Building 55 and the office that makes access cards for CERN, one can see a series of constructions that recall houses of cards. Here the playing cards are replaced by blank access cards, and the site's presence is signalled by elements of a map.

This issue of the CERN Courier includes special projects by the students of Carmen Perrin et Jean Stern's workshop in Geneva's Ecole Supérieure d'Art Visuel (ESAV) in the context of an exhibition of their work on the CERN site from 9-28 June. This collaboration between ESAV and CERN during the 1997-8 academic year benefited from the help and assistance of many CERN people, including Renilde Vanden Broeck, Gordon Fraser, Neil Calder, Freddy Buhler-Broglin, Georges Claude, Pierre Lefèvre, Daniel Treille, Hans Drevermann,... and the collaboration of Alain Léveillé, as well as support from the local Fonds Cantonal de décoration et d'arts visuels.



ALINE GAILLET: Théorie des six degrés de séparation

Frédéric : "Emma, rencontrée par hasard, nous continuons à nous voir régulièrement, amitié naissante". Renilde : "Wendy, ma collègue favorite, bureau avoisinant". Django : "Steve, musique". Silvano : "Patrick, mon ennemi". Frédéric : "François, chef de projet pour lequel j'ai travaillé, relation professionnelle parfois conflictuelle mais enrichissante pour moi". Jacques : "Pierre, troubadour de l'astrophysique". Thomas : "Richard, on prend le café ensemble". Udo : "Giovanna, amitié". Cécile : "Manuel, ami de Isabel et Paolo, ainsi que de Claudia et Charles-Henri". Frédéric : "Nicolas, collègue de travail, nous partageons une amitié qui nous permet de nous revoir de temps en temps". Laura : "Chiara, voisine". Owen : "Chris, pompier ami". Cédric : "Nick, nous jouons au volley ensemble". Thomas : "Frédéric, il est coopèrent comme moi". Jacques : "Mats, livreur de protons". John : "Cécile, on travaillait tous les deux pour la même boîte avant de venir au Cern". Jacques : "Michel, étudiant sous la même bannière voici deux lustres". Marc : "Pierre, compatriote arrivé au Cern en même temps que moi, copain d'un gars sympa rencontré au Maroc, et je me suis dit "pourquoi le copain d'un gars sympa ne deviendrait-il pas mon copain ?".

a) Comme ces dessins pour enfants où il faut relier des points en respectant l'ordre croissant des chiffres correspondents.

b) La ligne se brise: il en manque

c) Fonctions possibles pour les bâtiments manquants (1)

d) Fonctions possibles pour les bâtiments manquants (2)

e) De la maison pour les moutons aux maisons des escargots.

f) Des bâtiments mobiles sur le site.

ou
pourquoi 141 escargots, chacun d'entre eux marqués d'un des numéros faisant défaut dans la numérotation officielle des bâtiments du CERN, ont été lâchés le 4 juin 1998 sur le site du CERN de Meyrin (Genève, Suisse).

Pascal Cavin

COQUELICOT (*Papaver rhoeas*):
famille des Papavéracées

C'est notre coquelicot des champs, qu'on appelle encore Pavot rouge ou Ponceau.

Cette jolie plante, aux fleurs rouge sang s'ouvrant sur les étamines noires, nuisible aux cultures, pullule dans les moissons, sur les tâlus et les vieux murs. Ce sont les pétales séchés qui servent en herboristerie: étant donné leur fragilité, il faut les détacher avec soin et les sécher rapidement et méticuleusement; ils deviennent alors lie-de-vin par la dessiccation.

Julie Wälti: projet de semis de coquelicots sur le passage du tunnel du LEP

Around the Laboratories

Typical cumulative expenditure of an experiment at CERN's LHC collider, which will be commissioned in 2005.

CERN A special milestone

In a long road race, it is important for runners to know how far they have gone (and consequently how much further is left to run), and to have regular feeding stations for succour and support. Only then can they pace their effort over the distance and be sure of arriving in good shape.

In the long runup to the start of the experimental programme at CERN's LHC proton collider in 2005, these checkpoints are provided for each major experiment by a Resources Review Board (RRB), which comprises representatives of all funding agencies for that experiment, together with the management of CERN and of the experiment.

These RRBs meet twice each year to monitor the progress and status of their projects, especially the use and availability of financial and manpower resources. These RRB responsibilities evolve, in particular as the emphasis for the big Atlas and CMS detectors now switches from the initial research and development phase to actual construction.

In April, delegates to the Atlas and CMS Boards agreed on their respective Memoranda of Understanding which table in detail who is responsible for what and specifies the associated commitment. These agreements, pledging high technology contributions from all over the globe, now go to the respective funding agencies for signature. With these commitments assured, Atlas and CMS will be able to move from the R&D and design warmup to the main construction track and begin to run in earnest.

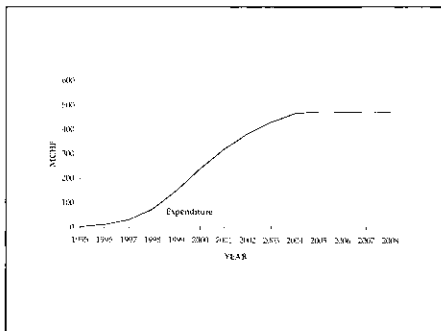

The other two major LHC experiments - ALICE and LHCb - are not far behind. With the interim memorandum signed by most partners, negotiations towards a final ALICE document have begun. For LHCb, input from the RRB will be a vital component in the leadup to approval of the Technical Proposal.

As an international organization with 19 Member States, CERN is used to international meetings, but the LHC experiment RRBs extend the geographical participation significantly wider. Atlas involves 143 research centres from 35 nations, CMS 149 and 31 respectively.

In terms of the commitments being pledged - 940 million Swiss francs for the two experiments together - these latest documents are among the most significant ever prepared in the history of the Laboratory.

Physics in space and from space

The decision by CERN and the European Space Agency (ESA) to set up joint specialist working groups underlines the new synergy of basic physics research, with some studies carried out in accelerator

laboratories and measurements by space-borne instruments complementing each other.

The establishment of three working groups, specifically for data acquisition and triggering, for 'outreach' and the public understanding of science, and for administrative matters, followed a visit of ESA Director General Antonio Rodotà to CERN on 7 May, accompanied by ESA Scientific Programme Director Roger Bonnet and head of ESTEC Space Research Martin Huber.

Outreach is a natural arena for collaboration. From their mutually opposite wings of the Big Bang physics stage, quarks on one hand and black holes on the other are beacon topics which readily interest inquisitive young minds.

Much of experimental particle physics was born in the study of cosmic rays earlier this century, and many of the major pioneer particle discoveries - the positron, the muon, strangeness,... - were made by detectors monitoring particles from space.

In the 1950s, many physicists turned aside from cosmic rays as giant accelerators enabled them to tap into intense beams. Particle physics, which had been born with the table-top experiments of Thomson and Rutherford once more became laboratory science, albeit on a different scale.

The new insights from fifty years of accelerator experiments now provide new understanding of cosmic phenomena and their interpretation in the Big Bang picture.

As laboratory energies increase, laboratory experiments reach further back in Big Bang history, when the common origin of forces now distinct was more evident. Our understand-

Physics in space. A view of the European Space Agency's FIRST/Planck mission, scheduled to fly in 2005. FIRST (top) is a far-infrared and submillimetre telescope, and Planck (below) will make precision measurements of the cosmic microwave background radiation.

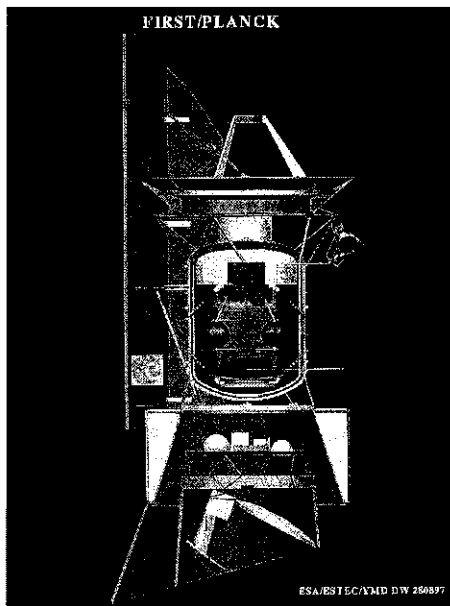

ing of the synthesis of electromagnetism and the weak nuclear force is now almost complete and awaits the attainment of the long-awaited Higgs mechanism, the root of the subtle symmetry breaking which makes electromagnetism and the weak force look superficially so different. Here the LHC will at least lift the Higgs curtain to one side, if not raise it completely. In parallel, heavy ion collisions, now at CERN and in the near future at Brookhaven's RHIC collider, and further ahead at the LHC, explore the quark-gluon plasma from which our conventional nuclear world crystallized.

As well as accelerator experiments, ground-based studies use the atmosphere or the Earth itself as an integral part of the 'apparatus' to access the more inaccessible parts of physics, particularly the neutrino sector. Here the 1987A supernova dramatically demonstrated how underground detectors could pick up signals from the distant cosmos and pioneered the science of neutrino astronomy.

Of all the fields of basic physics, gravitation, the feeblest of the forces but paradoxically the most important at large distances is the least explored at the quantum level. Gravitational waves, the carriers of the force, have yet to be detected. So far, ground-based studies have only produced limits for new generations of studies. The largest are the VIRGO project in Europe and LIGO in the US. Looking further ahead, the LISA (Laser Interferometer Space Antenna) has been accorded special status by ESA and will fly in the second decade of the new millennium, if not before.

As well as a scientific breakthrough, the observation of tiny temperature ripples in the cosmic microwave background radiation by the COBE satellite in 1992 was heralded as a synthesis of particle physics and cosmology. Other experiments are now running with this baton, which will eventually pass to ESA's Planck project in 2005.

Away from the purely scientific front, the infrastructures of European particle physics and space research have strong parallels. ESA provides the space vehicle and CERN the accelerator for the respective scientific payloads, the participating countries sharing most of the cost of the detectors.

As well as having their own Member State participation, both organizations are heavily committed to world-wide collaboration: ESA made a significant contribution to the Hubble Space Telescope while CERN's LHC attracts widespread support from beyond Europe.

While CERN's pioneer role in European scientific collaboration blazed a trail for further such ventures, CERN has also benefited from ESA's ideas to provide experience for young Member State engi-

neers at a formative stage in their careers.

FERMILAB 1998 is 1BC

The CDF experiment at Fermilab's Tevatron proton-antiproton collider has seen 19 examples of a new and very rare breed of meson, the B_c . With the B_c , the meson menu is essentially complete.

Strongly interacting mesons, of which the pion and the kaon are the most well known, are made of a quark and an antiquark bound together. There are six kinds of quark - up, down, strange, charm, beauty and top (in order of increasing mass), giving a wide choice on the meson menu.

Even when bound inside these mesons, heavy quarks can decay into lighter ones under the influence of the weak force, so the heavier mesons are highly unstable. However the top quark, discovered at Fermilab in 1995, is so heavy - 174 GeV, about the same as a nucleus of tungsten - that it is very susceptible to the weak force and decays 'weakly', quickly emitting an 80 GeV W particle, before it has a chance to bind 'strongly' with an antiquark and form mesons.

The heaviest mesons actually formed are therefore those containing the fifth - 'beauty' or 'b' - quark bound to another kind of antiquark.

The heaviest such meson, the upsilon, composed of a b quark and antiquark, and discovered at Fermilab in 1977, heralded the advent of the b quark.

MULTI HV CONNECTORS

22 OR 51 MINIATURE 3kV DC CONTACTS

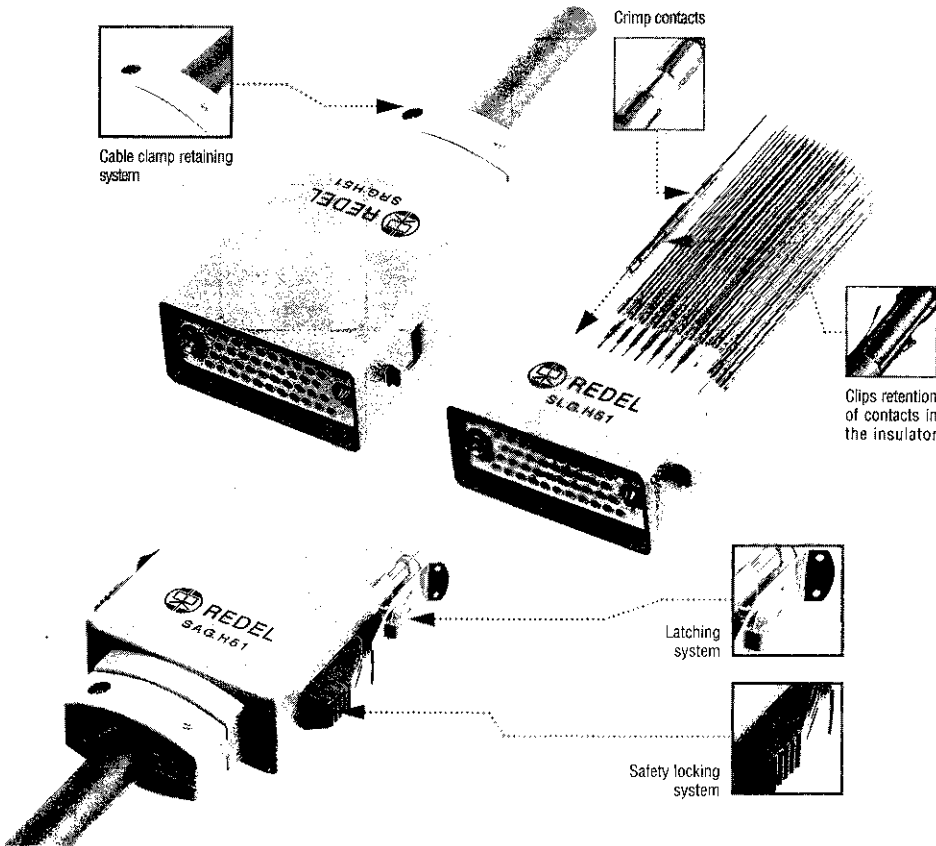

The new REDEL K & S series, using new miniature HV 3kV DC contacts, have been specially developed to meet the requirements of applications requiring high packing density in a compact design.

TECHNICAL CHARACTERISTICS

- High packing density (22 or 51 contacts)
- Miniature HV 3kV DC contacts for crimping and clips retention in the insulator
- Gold-plated contacts according to MIL-G-45204C type I, class 1
- Latching with safety locking
- Cable clamp retaining system for cable diameters 1 to 3.3 mm

LEMO SA
P.O. Box 194
CH-1024 Ecublens (Switzerland)
Tel: (+41 21) 691 16 16
Fax: (+41 21) 691 16 26
<http://www.lemo.ch>

Advertisements in CERN COURIER

Format A4

Monthly publication

All advertisements are published in both English and French editions. Second language versions accepted without extra charge.

Space (page)	Actual size (mm) width by height	Cost per insertion (Swiss Francs)			
		1 insertion	3 insertions	5 insertions	10 insertions
1/1	185 x 265	2200	2100	2000	1900
1/2	185 x 130	1300	1200	1100	1020
1/4	90 x 265	750	700	650	600

These prices include no entitlement to special placing.

Supplement for:

- one additional colour 1500 SwF

- 1/2 page 800 SwF

- Covers:

Covers 2 and 3 (one colour) 2200 SwF

Cover 4 (one colour) 2700 SwF

Publication date 1st of month of cover date

Closing date for

positive films and copy 1st of month preceding cover date

The cost of making films and of translation for advertisements are charged in addition.

Screen offset 60l/cm (150 English)

Advertisements cancelled after 1st of month preceding cover date will be invoiced.

These rates are effective for the year 1998

Inquiries for Europe:

Micheline FALCIOLA / CERN COURIER - CERN

CH - 1211 Genève 23 Suisse

Telephone: 022/767 41 03

Telefax: 022/782 19 06

Inquiries for the rest of the world:

please see page III

GEC ALSTHOM

A commitment to excellence in applied superconductivity

Wires

- NbTi / Cu
- NbTi / CuNi / Cu
- NbTi / CuNi
- Nb₃Sn

- For**
- MRI - MRS magnets
 - Collider magnets
 - Detector magnets
 - SMES applications
 - Fusion applications

Cables

- Aluminium jacketed conductors

AC Applications

- Current limiters
- Transformers
- Generators

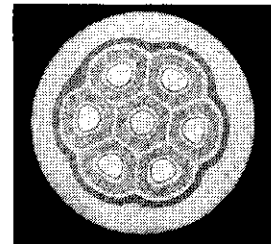

Gec Alsthom one of the world leaders in superconducting cables and wires

For any further information, please contact us

GEC ALSTHOM

POWER GENERATION

3, avenue des Trois Chênes - 91018 Belfort Cedex, France
Tel. +33 103 84 55 32 26 - Fax -33 103 84 55 16 15

The B_c meson, composed of a b quark bound to a charm antiquark, has been found by the CDF experiment at Fermilab's Tevatron proton-antiproton collider. The new particle was found through its decay into a J/ψ and an electron or a muon, with an accompanying neutrino, and with the J/ψ subsequently decaying into two muons. This shows the signal and background contributions.

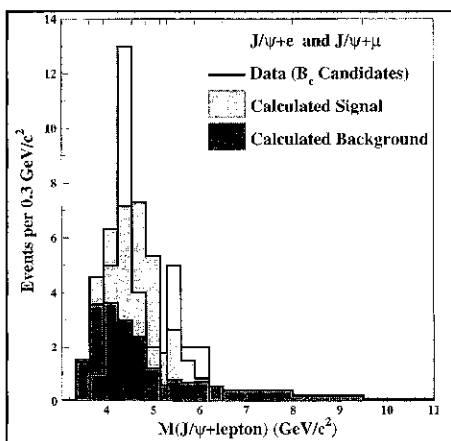

Mesons with a b quark bound to a lighter antiquark are collectively known as B particles. The lightest, with a mass of 5.3 GeV , made of a b quark bound to an up or down antiquark, were discovered soon after the ψ .

It took another decade of careful work to uncover evidence for the next possibility, the B_s , with a b quark bound to a strange antiquark, and about 0.1 GeV heavier than the light B .

Now Fermilab and CDF lay claim to the B_c , with a b quark bound to a charm antiquark. The particle was found in the Tevatron's 1800 GeV proton-antiproton collisions through its decay into a J/ψ and an electron or a muon, with an accompanying neutrino, and with the J/ψ subsequently decaying into two muons. The signal, disentangled from 31 candidate events, has a mass of about 6.4 GeV , in line with quark theory predictions. The particle's lifetime is 0.46 picoseconds.

Several experiments at CERN's LEP electron-positron collider tried hard to find the B_c when LEP's collision energy was tuned to the mass of the Z particle at 91 GeV , and reported a few B_c candidates, but not enough to claim discovery. The hunt



On March 19, the Minister of the Interior of the German state of Schleswig-Holstein, Ekkehard Wienholz (left), and the Hamburg Minister for Urban Development, Willfried Maier (middle), signed an agreement at DESY covering planning requirements for the construction and operation of the projected TESLA electron-positron linear collider with integrated X-ray lasers. On the right is Björn H. Wiik, Head of the DESY Directorate.

had to be abandoned when the LEP collision energy was increased in 1995 and the experiments left their Z hunting ground.

Although a few mountain peaks have been sighted, B physics is still largely uncharted territory, and surveying it in detail is now one of the major objectives of world high energy physics.

In particular, the race is now on to collect enough B particles to become the first to explore the delicate mechanism known as CP violation (May, page 3), hitherto only seen with neutral kaons and then with difficulty, in the relative profusion which B physics promises.

The current runners in the B race are the Babar detector at the PEP-II electron-positron collider B factory at SLAC (Stanford), the Belle detector at the Japanese KEK laboratory's electron-positron collider B factory, CLEO at Cornell's CESR electron-positron collider, the HERA-B experiment at DESY's HERA electron-proton collider, and, last but by no

means least, the proton-antiproton collider experiments at Fermilab's Tevatron, which strengthens its claim on B territory with its latest finding.

DESY State treaty provides legal basis for planning linear collider

The international TESLA collaboration centred at the German DESY Laboratory in Hamburg is exploring the possibility of constructing an electron-positron linear collider with an integrated X-ray source based on low frequency superconducting cavities.

The availability and the cost of the linear collider site are important factors when comparing different linear collider proposals. In the TESLA Conceptual Design Report, two potential sites for the collider

Notables at International Workshop on JHF Science (JHF98), held at the High Energy Accelerator Research Organization (KEK) in Tsukuba, Japan, from 4 - 7 March: left to right Tom Kirk (Brookhaven), Bernard Frois (Saclay), Shoji Nagamiya (KEK), Hirotaka Sugawara (KEK) and Stan Wojcicki (Stanford).

were proposed - one at Fermilab, the other at DESY.

The DESY site has been presented to the local population and has found strong support in the local communities. A more formal step has recently been taken with the signing of an intergovernmental agreement between the neighbouring German states of Schleswig-Holstein and the Free and Hanseatic City of Hamburg.

The agreement, signed at DESY on March 19, provides the legal basis for the public planning procedure for the TESLA project. Such a public planning procedure is one of the essential prerequisites for the availability of the site and hence for the realization of the project. The agreement still has to be ratified by the parliaments of the two states.

In case the TESLA collider is built in Hamburg, civil engineering will have to be carried out in both states. The 33-kilometre tunnel will begin at the DESY site in Hamburg and run in a straight line 10 to 30 m below the ground beneath 15 towns and municipalities of the district of Pinneberg in Schleswig-Holstein.

The facility will require two experimental halls located on a new DESY site near the village of Ellerhoop, as well as seven cryogenic halls along the tunnel route, six of which will lie in the district of Pinneberg. Acceptable locations have been found for all the cryogenic halls.

In Germany, legal requirements provide that such a facility can only be built and operated after a formal public planning procedure has been carried out, in which private and public concerns are taken into account. The environmental impact has to be studied as well. Since individual states are responsible for these procedures, two of them would be required: one in Hamburg, the other in Schleswig-Holstein. In the agreement, both



states decided that only one such planning procedure would be carried out by one common authority.

The formal course of such a public planning procedure is established by law and, if not well prepared, can sometimes last several years. It can only be initiated after an approval of the project. The signed state treaty allows the required expert reports to be obtained beforehand, which can considerably simplify and shorten the official planning procedure in case of the project's approval. Studies of the environmental impact of the linear collider will soon commence.

KEK International workshop on Japan Hadron Facility science

The worldwide enthusiasm for the Japan Hadron Facility was demonstrated at the International Workshop on JHF Science (JHF98), held at the High Energy Accelerator Research Organization (KEK) in Tsukuba, Japan, from 4 - 7 March.

Of the 441 registered participants,

exceeding by far the organizers' originally expectations, Japan counted 322, US 37, Canada 18, China 4, Taiwan 4, India 5, Korea 4, UK 8, France 3, Germany 10, Switzerland 10, Austria 2, Italy 7, and Russia 7.

The main goal of the workshop was to provide a clear picture of actual JHF experiments. Discussions covered experimental goals and the importance of physics, and the associated requirements for beamlines, detectors, experimental floors, and related facilities.

The workshop consisted of plenary sessions by keynote speakers and working sessions for each experimental facility, or 'Arena'. The K-Arena working group covers kaon and muon rare decays, neutrino physics, strangeness nuclear physics, physics with primary beams, hadron spectroscopy, and physics with antiproton and antinuclei.

The N-Arena covers solid target technology, new science with neutrons, and fundamental physics with neutrons. The M-Arena deals with next generation muon spin rotation experiments, and the E-Arena nuclear astrophysics, fundamental and nuclear physics with on-line radioactive beams, material science, post-accelerators, production targets and ion sources.

Left to right: A.G.Afonin, Yu.A.Chesnokov and V.M.Biryukov near the bent crystal station at IHEP accelerator.

A part of the working sessions of the E-arena constituted the KEK and TRIUMF (Canada) Joint Workshop on Physics and Techniques of Radioactive Nuclear Beams. In conjunction with JHF98, a Multi-Purpose Hadron Working Group Meeting for the OECD Mega Science Forum (Nuclear Physics) was also held at KEK from 3 - 7 March.

PROTVINO New channeling records

Nearly a decade after the pioneering demonstration of crystal extraction at Protvino in 1989, a new team under the leadership of V.I. Kotov has started at the same Russian Institute for High Energy Physics a new experiment on beam extraction with bent crystals (March, page 12).

This experiment aims to test as short as possible crystals to gain extraction efficiency from an increased number of proton encounters with the crystal. In the first run of 1998 this team established world record levels for the efficiency of charged particle extraction from crystals, over 40%.

This was achieved with a new O-shaped crystal made at St. Petersburg Nuclear Physics Institute. The idea, borrowed from the U-shaped crystals invented at CERN,

An O-shaped crystal - a monolithic 5 x 5 x 50 mm slab with the central part missing. The resulting "O" is compressed in its middle, but the beam passes through the edge, the idea being to minimize the bending due to deformations in other directions.

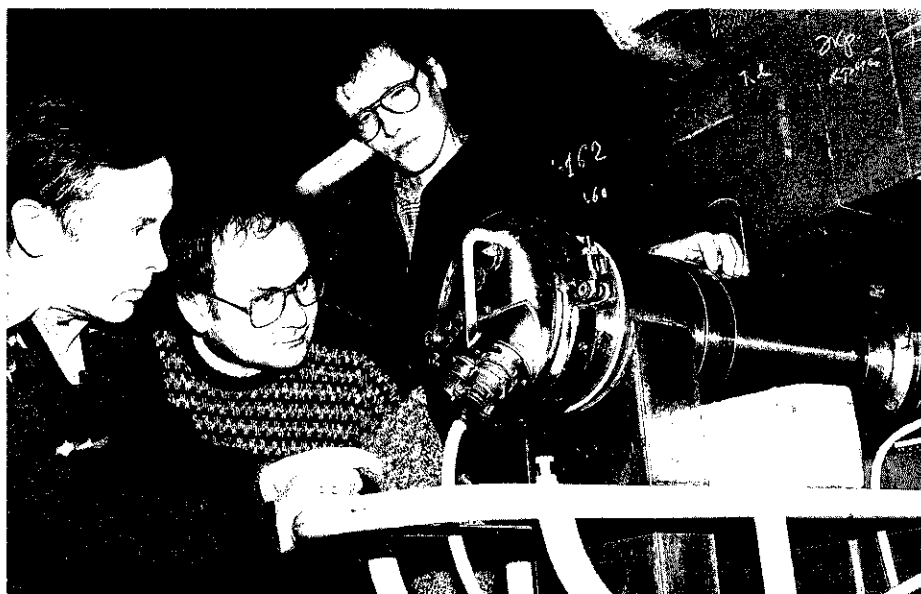

ensured perfect bending of the crystal slab without any angular distortions.

The CERN development was in collaboration with crystal specialists from the European Synchrotron Radiation Facility (ESRF), Grenoble, where accurately-machined crystals are required for monochromators, etc. The idea behind the U-shaped crystal was to try to avoid the distortions inevitable when solid crystals are bent, when bending forces applied in one direction produce deformations in other directions.

The silicon crystal was just 5 mm along the beam direction, and the central part, only 3 mm long, was

bent to give the 70 GeV protons a deflection of 1.5 mrad.

From 15 to 100% of the beam store (up to 3×10^{12} particles) was directed onto the crystal, and the extracted beam intensity was measured to be up to 6×10^{11} protons per spill of 1-2 s duration. The observed efficiencies (defined as the ratio of extracted beam to reduction in the beam store - see Figure) are in good agreement with the absolute predictions from simulations. During a spill, the extraction efficiency was also followed as a function of time, and its peak value was about 45-50%.

However researchers are sure that there is still a great potential for improvement. By adapting a new bending angle, around 0.5 mrad, and trying even shorter crystals, they anticipate over 90% extraction efficiency.

The required crystal, just 1 mm along the beam, is possible due to an invention by Mark Breese at Lisbon. Instead of bending a straight crystal slab, the idea is to grow curved crystals. The new technique should

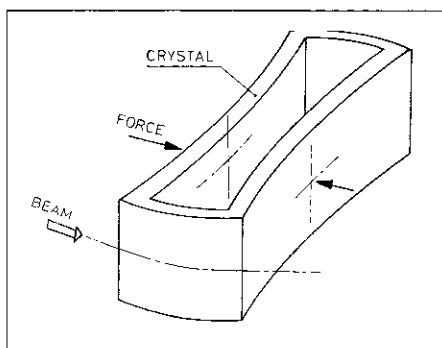

All Over Europe

LIFTING • TRANSPORTING • MOUNTING

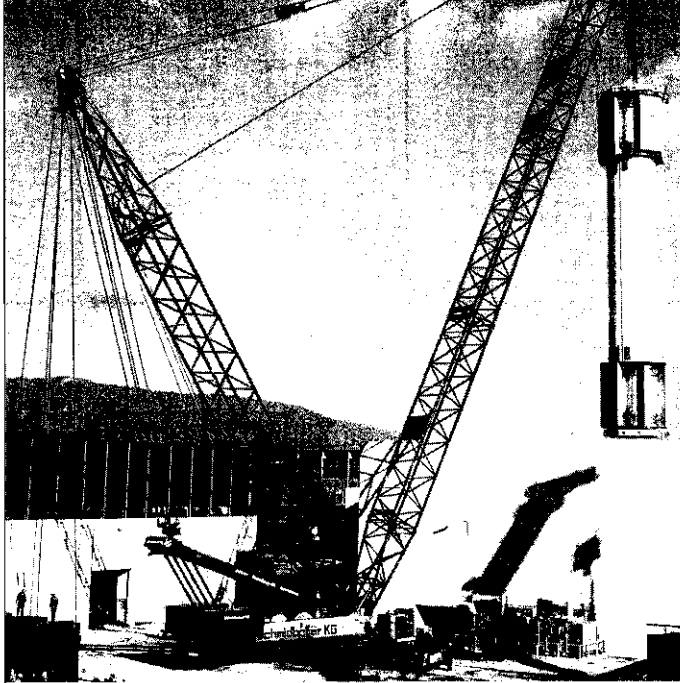

- crane work up to 1.100 t individual capacity, in combination up to 2.500 t
- industrial mounting of pre-assembled parts
- heavy load and special transports up to a total weight of 400 t
- plant transfers ■ machine transports ■ recoveries/salvages



Schmidbauer KG

Head Office Munich: 82153 Gräfelfing • P.O. Box 1149
82166 Gräfelfing • Seeholzenstr. 1 • telephone (089) 85 50 11 • telefax 85 11 24

BIMETALLIC TRANSITION JUNCTIONS



THE T+C / CEA KNOW-HOW :

for the assembly of different
metals under stringent reliability



VARIOUS APPLICATIONS

- Class 1 • Normal Cryogenics
- Class 2 • Advanced Cryogenics
- Class 3 • Space, nuclear, chemicals

STANDARD TRANSITION ON STOCK
QUALITY ASSURANCE

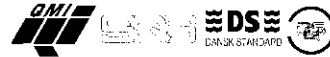

CALL FOR DETAILS

A. PINET Consulting Engineer
Phone : (33) 472.02.68.00
Fax : (33) 472.02.68.01



T+C

THEVENET + CLERJOUNIE

22, avenue Franklin Roosevelt - 69517 VAULX-EN-VELIN (France)

Move forward with **HTS** applications

using **Hoechst** superconductors

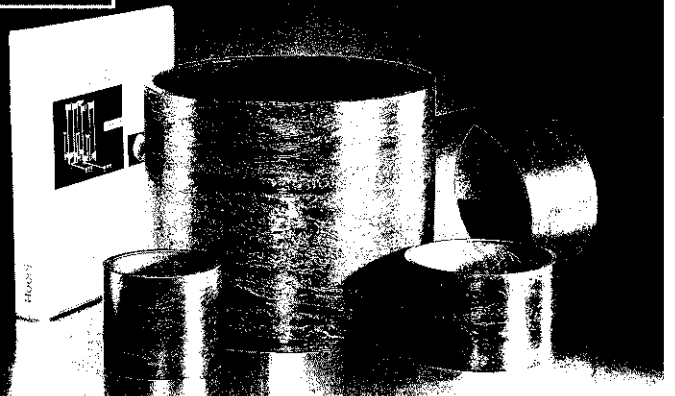

Our proprietary Melt Cast Process (MCP) for producing BSCCO 2212 bulk material permits the manufacture of a wide variety of shapes. It also allows the integration of low resistance silver contacts and easy mechanical processing.

HTS current leads based on MCP BSCCO rods and tubes from Hoechst are the first application of ceramic superconductors in electrical power engineering

with currents up to 10.000 A. A reduction of the heat load to the 4K level by more than a factor of 10 was achieved. This results in a significant reduction of the refrigeration costs and allows new innovative cooling concepts.

Parts of up to 400 mm in length or diameter can also be used in applications in the field of magnetic shielding, current limiters or others.

If you are interested in further information, please contact:

Hoechst AG
attn. Dr. S. Gauss,
Corporate Research
& Technology, HTSL
D-65926 Frankfurt, Germany
Tel: (+49) 69-305-16654
Fax: (+49) 69-305-16436
E-mail: hts@crt.hoechst.com

Hoechst

Pratvino - efficiency of crystal extraction as a function of the fraction of incident beam; measurements (crosses) and simulations (open circles).

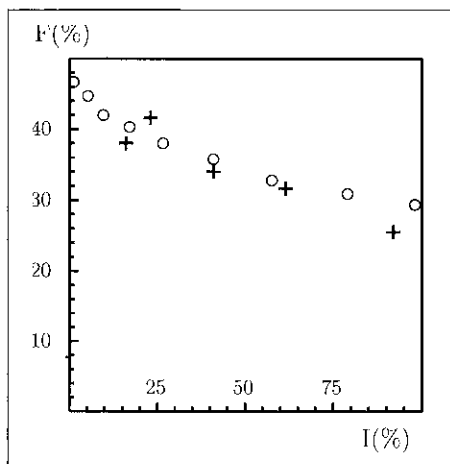

boost bent crystal applications at particle accelerators.

Updated information on IHEP crystal activities is available at <http://beam.ihep.su/~biryukov>.

Gus Voss (left) and Herman Winick have important roles in new working groups set up to look into the redeployment of Berlin's BESSY I synchrotron ring as a new centre for physics research in the Middle East.



Physics monitor

Synchrotron light in the Middle East

The synchrotron radiation from circulating particle beams, once considered an energy-sapping nuisance for high energy physics, has become a major scientific growth sector. This bright 'light', extending over a wide wavelength band, is used for a wide range of structure and materials research. The user appeal is also increasing geographically as more machines become available. Now the Middle East could soon have a synchrotron radiation source, established under the patronage of UNESCO.

The Steering Committee for Middle East Scientific Cooperation was established by Sergio Fubini in 1995 to promote contact between Israeli and Arab physicists. Its recent meeting in Uppsala, Sweden, chaired by former CERN Director General Herwig Schopper, was dominated by the idea to use the 800 MeV BESSY I synchrotron radiation source in Berlin as the basis for a Middle East Centre.

A new BESSY II machine has now commenced operations in Berlin, and although BESSY I is still fully subscribed, it will be shut down next year to save costs.

To prepare for the new project, two working groups have been set up, including scientists from Middle Eastern countries. The first group, chaired by G.-A. Voss of DESY, will look at the possibility of upgrading BESSY I to BESSY Ia and estimate the resources needed for its transport, reinstallation and operation.

The second group, co-chaired by ELETTRA (Trieste) director G. Margaritondo and H. Winick of Stanford, will identify scientific interest, explore instrumentation requirements and outline a training programme. First results from the groups will be presented at a meeting in Amman in November.

Other initiatives discussed at Uppsala included support for a Centre of Material Science in the Palestinian Territories and a meeting for young scientists at the International Centre for Theoretical Physics in Trieste.

The riddle of Majorana

Ever since the gifted Italian theoretical physicist Ettore Majorana mysteriously disappeared sixty years ago, there has been continual speculation about his fate.

Born in Catania, Sicily, in 1906, Majorana was one of the major players at the birth of modern nuclear and sub-nuclear research in Italy in the 1930s. His disappearance in 1938, followed shortly by the departure of Enrico Fermi, Emilio Segré and others for North America, was a major blow for a promising field of Italian science so soon after its establishment. (Later, thanks in particular to the unselfish efforts of Edoardo Amaldi, it was reestablished.)

Ettore Majorana 1906-38

As a student at Rome, the young Majorana was first attracted to engineering, where his mathematical prowess and calculational ability soon impressed his colleagues, among them Emilio Segré.

At this time, Orso Mario Corbino, influential politician and chairman of Rome physics, was pushing for an increased national effort in physics. The figurehead for this effort was Enrico Fermi, recently returned from Göttingen.

Among the gifted students attracted to Fermi's new school were Rasetti, and Segré, who recalled vividly the vivacity of the young Majorana, 'converted' to physics after hearing a 1928 Fermi colloquium.

Majorana's first research contributions were in atomic spectroscopy, chemical binding and atomic spin, and in 1932 his interest shifted to subnuclear particles. Chronically self-effacing, he was reluctant to publish his achievements, but his ability always impressed his contemporaries.

In 1932 the famous Joliot-Curie paper reported on the production of protons by wax irradiated by the outcome of beryllium bombarded by alpha particles. Majorana was reported to have remarked immediately that here was evidence for the production of a heavy neutral particle, a conclusion traditionally attributed to the subsequent study by Chadwick.

Majorana then turned to the problem of nuclear forces, where he investigated the idea of exchange mechanisms. Reporting this work at a meeting in Paris, Fermi spoke of 'Majorana forces', developments ultimately overshadowed by the decisive contributions of Heisenberg.

In Copenhagen (Bohr) and Leipzig (Heisenberg), Majorana met many of the leading theorists of the day. Returning to Italy posed the problem



of finding a permanent position, which in Italy is traditionally done by open competition. Majorana's treatise 'A symmetrical theory of electrons and positrons', invoked the existence of a neutral particle which is its own antiparticle (what is now known as a Majorana neutrino, as opposed to a conventional neutrino, which has a separate antiparticle).

This work gained Majorana the chair of Theoretical Physics at Naples Regia University in 1937, where Antonio Carrelli was head of department.

His initial lectures were well prepared and equally well received. However despite his involvement and responsibilities, Majorana continued to be vulnerable to the psychological torment which had racked him for many years. Others at Naples report him avoiding eye contact and places where there were people.

On 25 March 1938 he wrote to Carrelli

"I have taken a decision which has become inevitable. There is not one iota of egoism in this, but I am

conscious of the trouble that my unexpected disappearance will cause you and the students. I ask you to forgive this too, but especially for having betrayed all the faith in me and the sincere friendship and the sympathetic understanding you have demonstrated over recent months. I also ask to be remembered to those whom I have come to know and appreciate in your Institute, particularly Sciuti, of all of whom I shall keep fond memories, at least until 11 o'clock tonight and possibly even after."

Majorana embarked for Palermo on the ferry, arriving the following morning, where he enigmatically cabled Carrelli

"I hope you received the telegram with the letter. The sea has refused me ('il mare mi ha rifiutato') and I shall return tomorrow to the Albergo Bologna (Naples) probably travelling on this same packet (the Palermo-Naples steamship also acted as a mail ship). I still intend to give up teaching. Don't think of me as a young heroine out of an Ibsen play because it's not like that at all. I can provide further details if you wish."

The next day the ferry arrived back in Naples, with no Majorana aboard. Majorana was never seen or heard from again, despite in-depth police enquiries, the offer of a reward, and the personal intervention of Mussolini. Some insisted that he had been aboard the returning ferry from Palermo, and had disappeared into monasterial seclusion, but his previous 'il mare mi ha rifiutato' suggested that he drowned. The whole of Italian science mourned both a tragic personal loss and the disappearance of such a promising talent that could have gone on to produce so much.

As Enrico Fermi said 'Few are the geniuses, like Galileo and Newton.

ATMION™

WIDE-RANGE-MANOMETER

NEW

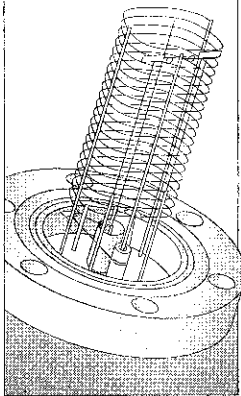

The new *ATMION* gauge combines well-proven vacuum measurement techniques with the high demands of modern vacuum systems.

Its benefits:

- Vacuum measurement from atmosphere to UHV with one single gauge
- Automatic change between measurement principles (Pirani/Bayard-Alpert)
- Power supply and controller directly positioned at the gauge head
- Maintains UHV rating with state of the art ceramic to metal seal
- Usable with an IBM PC or optional display unit

VACOM

Vakuum-Komponenten und -Messtechnik
Handelsgesellschaft mbH

Brändströmstr. 14 • D-07749 Jena
Phone +49-3641-4275-0 • Fax +49-3641-4275-24
WWW homepage: <http://www.vacom.de>

**10⁻ⁿ
mbar**

Your partner for a full service:
prepress – printing – binding –
distribution

lannoo

LANNOO PRINTERS
Kasteelstraat 97, B-8700 Tielt-Belgium
Tel. 32 51 42 42 11 – Fax 32 51 40 70 70

Powered Crates

Further to all our **CERN approved CERN-Spec. Crates**
NIM-, CAMAC-, FAST BUS-, VXI- and VMEbus
Wes-Crates supplies other Crates based upon these Systems.

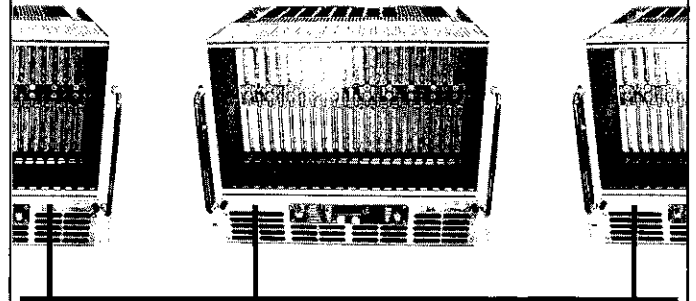

CAN remote control

ISO Layer 7: CANtrol®
user defined
CAL

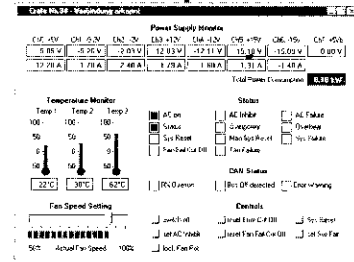

- 160 pin J1/J2
- opt. 95 pin J0 (2 mm)
- +3.3V/48V
- more user def. I/O-pins
- slot geographical adress
- EMC
- ESD
- injection / extraction handle
- slot keying
- rear I/O transition boards
- fast 2 edge protocol
- ...and more features

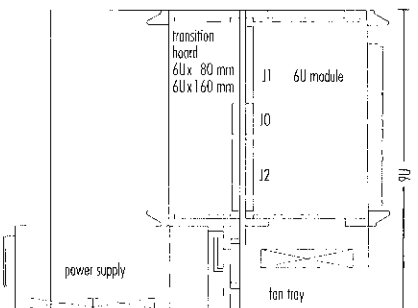

VME 64 Extension Compliance

Every **CERN-Spec.** so far has given rise to a **CERN-approved Crate** from:

Crates and Power Supplies from WES-Crates are flexible because of modular systems.

WES-Crates

Wes-Crates GmbH
Pattburger Bogen 33
D-24955 Harrislee/Flensburg
Germany
Telefon 0461 - 77 41 77
Telefax 0461 - 77 41 41
International +49 461
E-mail: sales@wes-crates.de



Zertifiziert nach
ISO 9001
Germanischer Lloyd
Certification

Your contact in Geneva: HiTech Systems Sa, Avenue Wendt 16,
1203 Geneva, Tel.: 022 / 344 77 88, Fax: 022 / 45 65 51
Your contact at PSI and ETH Zürich: Dipl.-Ing. Kramert AG,
Villigerstr. 370, CH-5236 Remigen, Tel.: 056 / 284 15 55, Fax: 284 50 55

But Ettore Majorana was one of them.'

Periodically there was talk of him having been seen. In the late 1970s, there were rumours that he had been sighted in South America. Later he was reported to be alive and well as a Sicilian shepherd.

The forces and neutrinos to which Majorana gave his name serve as a lasting memorial. The internationally known "Ettore Majorana" Centre for Scientific Culture in Erice, Sicily, also honours the name.

At a recent commemorative meeting at Naples, Gilda Senatore, a student in the theoretical physics course given by Ettore Majorana, recalled his 1938 lectures.....

"It is very difficult to describe Ettore Majorana, known to us only in the role of university lecturer, even for me, who, as a pupil, was for a short time close to him. His stay in Naples was very brief, a little more than three months, and during this time he gave 25-26 lessons from 13 January to 24 March 1938.

Prior to coming to Naples he had never given a regular course, and thus his exceptional stature lacked the final piece of the picture: that of lecturer. Moreover his teaching qualities can be measured only through these lessons in Naples.

I relate, as accurately as memory will allow, of how this complex figure appeared to us. It might have been better had we been given more information about him prior to his arrival.

This, I feel, was a mistake, because Majorana was a genius in his field, but he was also, and above all, an acutely sensitive and anxious man, and these factors certainly influenced his personality, as did his personal motivations.

Having attained an honorary professorship for exceptional scientific merit at Naples, where there was no

research centre in his field, I do not believe that he was told to expect only six students for his high level course. Majorana probably expected an environment which was rich in his research interests, and maybe he was disappointed. Before the inaugural lecture he wrote to his mother that "the institute was practically made up only of the figure of Carrelli, of the old assistant Maione and of the young assistant Cennamo".

Thrown into an environment that he had not chosen and that he knew nothing about, he set off on the wrong foot and this, to a certain extent, influenced his ultimate decisions. I believe that in Naples, Majorana felt quite literally alone for the first time in his life, and he probably felt extremely discouraged, without prospects.

Added to these difficulties was the fact that he had arrived in a state of profound depression, which, despite his efforts to conceal, we could nevertheless see. He greeted or replied politely to a greeting and sometimes smiled timidly. We could see that he was a very good and sensitive man, but he was never extrovert or inviting. He was invariably extremely evasive. In the dark long corridor on the ground floor he would always walk in the shadow of the walls, silently and alone.

In his lectures, he was very clear in his treatment, outlining it each time at the beginning of the lesson with a wealth of detail, giving more weight to physics rather than the mathematics. However his blackboard calculations were not always easy to follow. To make matters more difficult, Majorana's approach to problems was extremely original. It was therefore impossible for us to follow from any textbook; only our notes, taken during lessons and subsequently pooled, could help.

During some of the most dry and heavy lessons, those which essentially looked at the application of mathematical methods to physical phenomena, Majorana, forgetting for an instant the abyss between us, would write extensively on the blackboard, then suddenly, as if coming back down to earth, would stop, turn and look at us for a moment, smile and explain the concept in a more simple form. He never had any contact with us outside lecture hours, nor did he show any interest in our experimental work.

Certainly he had to ask Carrelli about each of us and Carrelli had to tell him which fields we worked in and our performance as third year "in-house" students, but that was where his interest stopped.

I am nevertheless convinced that if there had been greater communication from the outset, he probably would not have disappeared on 25 March. On that day, which was not a lecture day, he came to the Institute and stayed only a few minutes, a thing that he was not in the habit of doing.

From the corridor outside the small lecture room where I sat writing, he looked in through the door and called "Miss Senatore". He gave me a closed file: "Please take these papers, these notes. We'll talk about it another time". As he left he turned and repeated, "we'll talk about it another time". There was no time to ask for further explanations. The following day, Saturday, he was due to hold a class. Although I was disconcerted and surprised, I did nothing, just waited.

Soon after his disappearance, I was unable to attend the Institute regularly for personal reasons until just after the summer holidays.

Professor Cennamo became

Cryogenic Components



Manufacturing Line

- Cryogenic Valves
(Shut-off and Control Valves,
Vacuum Jacketed and also for
Cold Box Mounting)
- Special Valves for any Cryogenic
Applications
(Check-Valves, Pilot Cryogenic
Valves, Relief Valves etc.)
- Bellows Sealed Valves
(up to PN420).
- Cryogenic Transferlines and
Couplings
(Johnston and Multi-Coaxial
Couplings)
- Space Cryogenic Components
- Custom made Cryogenic
Components e. g.
Cryostats and Ejectors

Multi-Coaxial Coupling >

for Cryogenic Transferlines
(LHe inlet and GHe outlet or vice
versa, for cold box mounting)

WEKA AG · Schürlistr. 8 · CH-8344 Bäretswil · Switzerland
Phone ++41 (0)1 939 29 59 · Fax ++41 (0)1 939 29 63
E-Mail: info@weka-ag.ch

Für USA and Kanada: PROVAC LTD, POB 18411, Greensboro, North Carolina 27419
Phone (910) 282 6618, Fax (910) 288 3375, E-Mail: bollini@msn.com

Für Japan: NIPPON SANSO CORPORATION
PLANT & MACHINERY DIV., SPACE & CRYOGENIC EQUIPMENT DEPT.
6-2 Kojima-cho, Kawasaki-ku, Kawasaki-City, Kanagawa-Pref. 210, Japan
Phone 044 (288) 4063, Fax 044 (299) 4109
E-Mail: Kiyoshi_Ishiwata@sanso.co.jp, WWW: www.sanso.co.jp

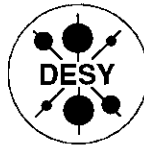
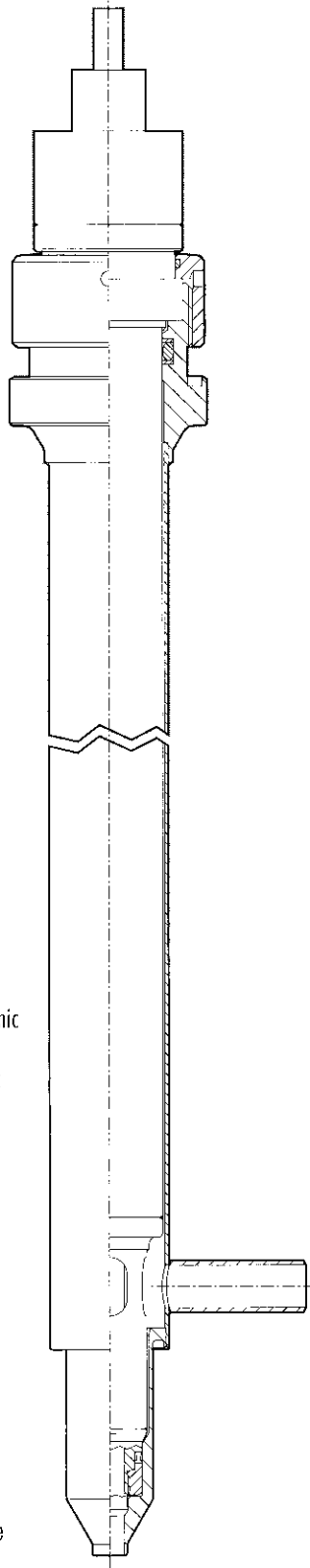

DESY, one of the leading laboratories in particle physics and synchrotron radiation research is offering a position for a

Physicist in the field of Radiation Protection

in the DESY radiation protection group. The position is permanent and the salary will be according to the German civil services lb MTV Angestellte.

The radiation protection group is responsible for radiation safety at all accelerators at DESY. The DESY accelerator complex comprises the two HERA storage rings, the injector storage ring PETRA II, the dedicated light source DORIS III, the preaccelerator chain with two linacs, two synchrotrons and the TESLA Test Facility. In addition, the group is developing the radiation safety concept for the TESLA linear collider and the integrated X-ray FEL. We are expecting the successful applicant to participate responsibly in the activities of the radiation protection group.

Applicants should have a Ph.D. in experimental physics, substantial scientific knowledge and several years of experience in the field of radiation protection at accelerators. In addition the applicant should be familiar with computer codes to calculate the thickness of shielding walls, personal doses, radiation fields, etc. Interested applicants with these qualifications should send their letter of application and three names of referees before 31.08.1998 to:

DESY Personalabteilung
Notkestraße 85 D-22607 Hamburg
Tel.: 49-40-8998-3628
Fax: 49-40-8998-4305

Women are especially encouraged to apply for this position.

UNIVERSITY OF CALIFORNIA, LOS ANGELES FACULTY POSITION IN ACCELERATOR PHYSICS

The UCLA Department of Physics and Astronomy invites applications for an appointment at the **assistant professor** level in the physics of particle beams and accelerators. This tenure-track position is available for a superior experimentalist with interests and demonstrated expertise in one or more of the following areas: particle beam and electromagnetic radiation instrumentation, next-generation rf linear accelerator design, subpicosecond lasers, free-electron lasers, novel x-ray sources, high intensity beam physics, beam-plasma interaction and advanced acceleration techniques.

The successful candidate will be expected to conduct a vigorous independent research program, complementing the existing strengths in particle beam physics at UCLA. Applicants should send a curriculum vitae with a list of publications, a statement of research interests, and the names and addresses of at least three references to:

Attention: Accelerator Physics Search
Prof. F.V. Coroniti, Chair
UCLA Department of Physics and Astronomy
3-174 Knudsen Hall
Los Angeles, CA 90095-1547

UCLA is an affirmative action, equal opportunity employer.

responsible for my degree thesis. After a few months I handed over the file Majorana had given me.

He kept it for a while, then gave it to the Director, Professor Carrelli, who was officially responsible for Majorana's belongings in Naples. I heard nothing more about it until 40 years later when I came upon the publication "Ettore Majorana - Lectures at the University of Naples". Those notes represented almost everything contained in the file that he had given me.

At the time I was unable to comprehend the significance of those papers. Looking back, I tend to think that it could have been a chapter, or a scientific paper, undoubtedly original, of a new and interesting part of the quantum mechanics programme which he had intended to use in the final part of the course.

To return to that 25 March, I think I can say that I was the last person to see Majorana before he caught the Naples-Palermo ferry that night. During the whole of the ensuing confusion, full of conjecture, I, who had the fortune to be his pupil, was left with a feeling of deep dismay and anguish over the sudden disappearance of such an illustrious scientist and incomparable Maestro."

The European Committee for Future Accelerators (ECFA) met in Amsterdam in April to survey the current Dutch particle physics scene. Flanking Ger van Middelkoop, director of the national NIKHEF Laboratory which hosted the meeting, are respectively incoming and outgoing ECFA Secretaries Allan Clark (left) of Geneva and ATLAS and Denis Linglin (right) of Lyon and CMS.

Particle physics in the Netherlands

At its meeting in Amsterdam in April to survey the current Dutch particle physics scene, the European Committee for Future Accelerators (ECFA) was particularly impressed by the coordination provided by the national NIKHEF Laboratory, which now underpins a strong tradition in particle physics. The formerly distinct NIKHEF particle and nuclear branches have now been merged, with a significant shift of interest towards the particle side.

Research

Of the 50 or so high-energy experimentalists in the Netherlands, about 40 have a position with FOM, Foundation for Fundamental Research on Matter (see below), while the remainder have university positions. There are also about 60

graduate students and postdocs, paid by FOM and the universities.

Over 100 technical support staff are available at NIKHEF, which operates on its Amsterdam site the AmPS electron accelerator for nuclear physics (January 1997, page 5 - 0.7 GeV with polarized beam), but this will be closed at the end of the year. The new AGOR superconducting cyclotron has recently been commissioned at Groningen, in a collaboration with the French Orsay Laboratory (January 1997, page 8).

While the nuclear physics community in the Netherlands has traditionally been strong, many of these physicists are now gradually turning to particle physics, and the new NIKHEF structure facilitates such transfers.

The main effort for CERN research comes from NIKHEF, which also has a presence in Amsterdam (University of Amsterdam and the Free University of Amsterdam), Nijmegen and Utrecht.

There is a strong Dutch involvement in the LEP electron-positron



In parallel with their meeting at the Dutch NIKHEF Laboratory in Amsterdam, the European Committee for Future Accelerators (ECFA) also visited ESTEC, the European Space Agency's technical centre at Noordwijk. Here, Rudeger Reinhard, secretary of the European Space Agency's Fundamental Physics Group, explains the Giotto satellite.

collider, with participation in Delphi (Amsterdam) and in L3 (Amsterdam and Nijmegen). Physicists involved in the Chorus neutrino experiment, the SMC Spin Muon Collaboration (Amsterdam) and in heavy ions (Utrecht) originate mainly from nuclear physics. Together, this effort represents about 20 scientists. There are 3 Dutch groups (25 scientists in total) working at the HERA electron-proton collider at DESY, one in Zeus, one in Hermes and one in HERA-B.

There is a strong interest in CERN's LHC collider with 25 scientists (Amsterdam and Nijmegen) associated with ATLAS and in particular its muon spectrometer. Dutch participation in ALICE (silicon strip detector) develops from heavy ion work at the SPS (NA 57). There is growing interest in LHC-B.

Participation in the D0 experiment at Fermilab's Tevatron collider is considered as a valuable preparation for research at ATLAS.

Also within NIKHEF is R&D for research on gravitational waves (the Grail cryogenic detector).

NIKHEF, which receives 80% of its support from FOM and 20% from its member universities, provides a firm foundation for national involvement in particle physics research. The majority of long-term positions are with NIKHEF, and FOM accepts long term commitments extending over the construction and exploitation of large facilities.

Particle physics support at NIKHEF (including salaries paid by FOM and the universities) runs to some 24 million Swiss francs annually. The Dutch investment in the LEP detectors (up to 1986) amounted to 6.2 million Swiss francs and in Zeus 3.5 million Swiss francs (up to 1991). The 12 million Swiss francs obtained for the LHC detec-



tors, mainly for ATLAS, but also for ALICE and LHCb, is however considered to be on the low side compared to the standard annual Dutch contribution to CERN.

The Netherlands has an illustrious tradition in theoretical physics. The current Dutch population of 28 theorists with permanent positions and 35 PhD students are mostly associated with six universities - Leiden and Groningen as well as those associated with NIKHEF. They are grouped, under FOM, in a High Energy Working Community. National seminars and schools, open to international attendance, cover topical subjects. As on the experimental side, some nuclear theorists are turning to high-energy physics. Through its fellows and associates programme, CERN has maintained good contact with theoretical physics in the Netherlands.

Overall, with the organization of Dutch particle physics in the capable hands of NIKHEF, the general

outlook is good. The restructuring of the laboratory has been a success, allowing for a moderate increase in research staff, and there is significant transfer between NIKHEF and the universities. Of the PhDs, about half go eventually to industry. This applies equally to experimentalists and to theorists. A centre for Plasma Physics and Radiation Technology provides graduate and postgraduate programmes on particle accelerators. On the downside there are worries about not attracting enough students to particle physics.

Organization and funding

The Dutch contribution to CERN, which currently amounts to about 38 million Swiss francs, is paid through the Directorate for Research and Science Policy (DWB). This body has three main budget lines, the first for the Universities, the second to

Going Dutch - Portuguese LIP laboratory director Gaspar Barreira (left) and DESY Director Bjørn Wiik.



As well as meeting at the Dutch NIKHEF Laboratory in Amsterdam, the ECFA also visited ESTEC, the European Space Agency's technical centre at Noordwijk, for a review of current space science activities, including current projects for investigating fundamental physics in space.

the National Research Organization (NWO), and the third for international collaboration (mainly CERN, the European Southern Observatory, ESO, and the European Molecular Biology Laboratory, EMBL). DWB also supports the Royal Netherlands Academy of Sciences.

The DWB, which, together with FOM (under NWO), is responsible for home support, is under the Ministry of Education, Culture and Research. The NWO has several sector councils (Gebiedsbesturen), with the "E" sector covering space science, astronomy, chemistry, mathematics, computer science and fundamental physics. One subsector is FOM, the Foundation for Fundamental Research on Matter, and NIKHEF is the largest entity under FOM. FOM Council Chairman A.R. de Monchy visited CERN in 1997. FOM director K. H Chang is also chairman of EUPRO, the European Union of Physics Research Organizations.

FOM and the participating universities are responsible for NIKHEF. While the universities pay for tenured university staff and some support, the largest fraction of the support for research comes through FOM.

NIKHEF was created in 1975 from

the former IKO (Institute for Nuclear Physics Research), and the home base for bubble chamber physics at Amsterdam and Nijmegen. It initially was responsible for the strong Dutch involvement in LEP (in particular muons in L3 and the barrel RICH in Delphi).

The National CERN Committee reports directly to DWB. Its members, nominated by the Royal Dutch Academy of Science, advise CERN Council delegates and deal with the CERN fellowship programme.

CERN and Dutch Industry

Many Dutch firms specialize in mechanical and electronic engineering and in instrumentation. Those supplying large research facilities have set up the Dutch Scientific consortium to coordinate their activities, while NIKHEF acts as a focal point for the industrial liaison activity. A Dutch company (HOLEC) has been involved in R&D for CERN LHC dipoles. With Dutch orders for CERN not as high as they could be (return coefficient 0.51), there are regular industrial exhibitions at CERN.

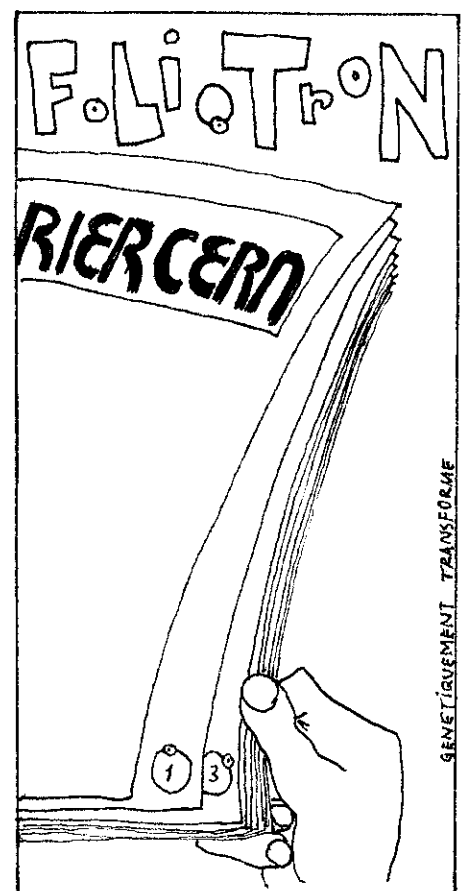

Indiana University Experimental High Energy Physics Postdoctoral Research Associate Position

The Department of Physics at Indiana University invites applicants for a postdoctoral research associate position to work with the experimental high energy physics group on the D0 experiment at Fermilab. The position will be available as early as July 1998 and will be based at Fermilab.

The successful candidate is expected to participate in the new Indiana effort on the central scintillating fiber tracker and its construction, testing, and commissioning for the D0 Run II Upgrade Detector. In physics analyses the group's interests for the Run II data are in b quark physics and searches for supersymmetric particles and Higgs bosons.

Applicants should have experience in hardware, software, and physics analysis, and must have a Ph.D. degree in elementary particle physics. Interested candidates should send a cover letter and a curriculum vitae, and arrange for three letters of recommendation to be sent to: **Prof. R. Van Kooten, Department of Physics, Indiana University, Bloomington, IN 47405.**

Screening of candidates will begin immediately; application materials should be received by July 1, 1998 to receive full consideration. Additional information can be obtained by contacting Rick Van Kooten (Rick.Van.Kooten@cern.ch). Indiana University is an Equal Opportunity/Affirmative Action Employer.

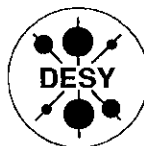

DESY is a physics research laboratory with 1400 employees and more than 3000 guest scientists from Germany and abroad. The scientific programme includes research in particle physics and synchrotron radiation.

DESY invites applications for the position of the

Deputy to the Research Director

which becomes available in fall of 1998.

The Deputy assists the Research Director especially in administrative matters. He/she will be responsible for the recruitment and supervision of the non-scientific staff, finance controlling, budget matters as well as management of technical appliances and is in charge of the domestic and foreign guests.

The position requires a Ph.D. in physics (in high energy or nuclear physics), management experience and a strong interest and knowledge in economic and business administration. Good knowledge in spoken and written English is essential.

The salary is determined according to tariffs applicable for public service work (BAT lb/la).

Handicapped applicants will be given preference to other applicants with same qualification.

Women are especially encouraged to apply for this position.

Interested persons should send their application, including curriculum vitae before 1st September, 1998 to

Prof. Dr. Albrecht Wagner
DESY
Notkestraße 85
D-22607 Hamburg
Phone: 49-40/8998-3000

Deutsches Elektronen-Synchrotron DESY



DESY invites applications for a **senior scientist** (equivalent to a tenured full professor at an university) in experimental particle physics at the institute in Zeuthen (Berlin).

The research program at DESY is focused on the experiments at the Electron-Proton Collider HERA and R&D work leading to the construction and exploitation of the next generation of an e^+e^- linear collider.

The candidates should be internationally recognized with demonstrated leadership abilities. The successful applicant is expected to take a leading role in the research program of DESY.

DESY encourages especially women to apply.

Application and suggestions of candidates should be sent before September 30th, 1998 to Prof. Dr. B.H. Wiik, DESY, Notkestraße 85, 22607 Hamburg, Germany.

Further information about the position can be obtained from Prof. Dr. B.H. Wiik.

U.S. DEPARTMENT OF ENERGY DIRECTOR, NUCLEAR PHYSICS DIVISION OFFICE OF HIGH ENERGY AND NUCLEAR PHYSICS OFFICE OF ENERGY RESEARCH

\$106,412 to \$125,900 per annum
ETR 98-ES-10-028

The U.S. Department of Energy is seeking applicants for the position of Director, Nuclear Physics Division, Office of High Energy and Nuclear Physics, in the Office of Energy Research. The incumbent will be responsible for providing technical and management direction for the Nuclear Physics Division's activities supporting the Department's and nation's efforts to advance the knowledge of the fundamental interactions, properties and structure of atomic nuclei. The incumbent will assure adequate financing for the Nuclear Physics program; review and determine the overall direction of nuclear Physics research programs, arrange and conduct interlaboratory and interprogram meetings and conferences, and provide direction and management for work performed by contractors. A thorough knowledge and understanding of nuclear physics, as well as extensive background and experience based on training and substantial research experience in nuclear physics, are necessary.

To be eligible for consideration, applicants must submit a completed application or resume, and/or an Optional Form 612, "Optional Application for Federal Employment." Details of all information required to apply and further information should be obtained from DOE Vacancy Announcement ETR 98-ES-10-028. This announcement can be faxed to you by calling 202-586-1705.

Applications must be postmarked no later than July 3, 1998, and should be sent to the U.S. Department of Energy, Executive Resources Division, Room 4E-090, 1000 Independence Avenue, SW, Washington, DC 20585

The Department is an equal opportunity employer.



Department of Physics

Research Officer and Research Assistants in Experimental Particle Physics or Particle Astrophysics

Applications are invited for a post of Research Officer and two or three posts of post-doctoral Research Assistant in experimental particle physics or particle astrophysics.

Research Officer is a fixed-term academic appointment with the same salary and conditions as Lecturer, but with a limited teaching load. The post is available immediately and will be for three years in the first instance, with the possibility of extension for a further two years. The salary will be on the University Lecturer Scale (£16,045 to £29,875 pa, depending on age).

The successful candidate will be expected to make substantial contributions within our research programme during the coming five years. Oxford has the largest particle physics group in the UK with a wide programme covering experiments at accelerators and in particle astrophysics. This includes preparations for the LHCb, ATLAS, and MINOS experiments and an upgrade to the ZEUS detector. Analysis of ZEUS and DELPHI data is continuing and we plan to begin participation in CDF software development and analysis. The SNO solar neutrino experiment and the CRESST dark matter search will soon be coming into operation. We have a continuing programme of cryogenic detector development for applications such as dark matter and x-ray astronomy and are also involved in the ANTARES R&D programme for neutrino astronomy. More information on our programme can be obtained from our web page: <http://www.pnp.physics.ox.ac.uk>

Post-doctoral Research Assistant for CDF: We are looking for an outstanding post-doctoral researcher to participate in our planned involvement in the CDF experiment at the Fermilab Tevatron. An application to PPARC for funding of the post is pending. The post would be initially for a period of two years with an expected starting date in the fall of 1998. The salary is on the RS1A scale (currently £15,159 to £22,785 pa) with the starting salary dependent upon experience. There is an additional foreign living allowance while based in the U.S. depending on the exact circumstances and pay scale of the applicant.

The successful candidate will provide leadership in the level 3 trigger software effort for the CDF-Oxford group during the first two years and be heavily involved in the

preparations for Run-II physics analysis which is expected to begin early in the year 2000. The post-holder will be based primarily at Fermilab near Batavia, Illinois in the United States. Experience with object oriented C++ coding and Fortran legacy problems as well as with fast particle physics trigger algorithms would be beneficial but is not required.

Post-doctoral Research Assistant for CRESST: We are looking for a person experienced with cryogenic detectors operating in the 10-100 mK range to work on the CRESST dark matter experiment in Gran Sasso, Italy or on cryogenic detector development in Oxford. Experience with low background techniques (for work in Gran Sasso) or in low temperature physics (for work in Oxford) is desirable. This post is on the RS1A pay scale and is available immediately. It is funded by an EU TMR Network on Cryogenic Detectors and only people who are nationals of the EU or associated states but not of the UK are eligible. Applicants must also be no more than 35 years of age. For posting in Gran Sasso the candidate should not be an Italian national.

Post-doctoral Research Assistant: Depending on the outcome of the Research Officer selection and on other local developments we may also appoint an additional Research Assistant to strengthen our programme in an area different to that of the Research Officer. Applications are also invited for this post.

Applications including a description of research experience and interest, a curriculum vitae, and a list of up to ten most significant publications should be sent to our secretary Miss Caroline Hinton, Nuclear & Astrophysics Laboratory, Keble Road, Oxford OX1 3RH, Fax 0044 (0) 1865 273418, e-mail c.hinton@physics.oxford.ac.uk to arrive no later than 31 August 1998. Your application should state for which post or posts you are applying. Please ask three referees to send letters of reference to Miss Hinton at the above address to arrive by the closing date. Further particulars on these posts are available from Miss Hinton.

The University is an Equal Opportunities Employer.

TENURE TRACK FACULTY POSITION Experimental High Energy Physics Carnegie Mellon University

The Department of Physics at Carnegie Mellon University invites applications for a junior tenure track faculty position in the area of experimental particle physics. The present program consists of experiment 781 at FNAL and the L3 experiment at CERN. Future activity is planned at the LHC, as members of the CMS detector and in the development of a BTeV facility at FNAL.

Applicants for the position should have postdoctoral experience and demonstrated ability in both instrumentation and analysis. The successful candidate is expected to assume a leadership role in future experiments. Applicants should be committed to excellence in undergraduate and graduate education.

The position will become available starting September 1999. Applications and three letters of recommendation can be sent via e-mail followed by a paper copy, to:

High Energy Search Committee
ATTN: Prof. A. Engler
Department of Physics
Carnegie Mellon University
Pittsburgh, PA 15213, USA
(e-mail: engler@cmphys.phys.cmu.edu)

Applications arriving until October 15, 1998 will be considered.

*Carnegie Mellon is an equal opportunity /
affirmative action employer*



The Deutsche Elektronen-Synchrotron, DESY in Hamburg, member of Hermann von Helmholtz-Gemeinschaft Deutscher Forschungszentren, is one of the world's leading research centres for high-energy physics. Within the framework of a broad international collaboration, DESY coordinates studies towards a next generation electron-positron Linear Collider based on superconducting accelerator technology (TESLA).

We would like to offer a position for a

Scientist

in the field of accelerator physics/accelerator design.

The topics of interest are:

Optimisation of the overall design of TESLA including all sub-systems required for the Linear Collider, studies of beam dynamics and stability and preparation of experiments relevant for the future project. Thus participation in the theoretical analysis and design work in the field of linear accelerators and storage rings is required.

Applicants should have a Ph.D. in physics and experience in the field of interest. The contract will be unlimited and the salary will be according to group Ib of the "Bundesangestellten-Tarif".

Code-number 56/98

Handicapped applicants with equal qualifications will be preferred.

DESY is interested in advancing the professional development of women and would like to encourage women to apply for this position.

Written applications complete with certificates and at least two letters of reference should be sent to our personnel department before August 15th 1998.

DEUTSCHES ELEKTRONEN-SYNCHROTRON DESY

Notkestraße 85, D 22607 Hamburg, Germany
Telefon 49-40/8998-3197

People and things

In front of the control room of the Opal experiment at CERN's LEP electron-positron collider: centre, Masashi Akiba, international science programmes coordinator of Japan's Monbusho ministry, flanked by Akinori Mori, first secretary of the Japanese mission to Geneva, and Sachio Komamiya of Tokyo. Japan recently announced a further contribution to CERN.

External correspondents

Argonne National Laboratory, (USA)
D. Ayres

Brookhaven, National Laboratory, (USA)
P. Yamin

Jefferson Laboratory, (USA)
S. Corneliusen

Cornell University, (USA)
D. G. Cassel

DESY Laboratory, (Germany)
Ilka Flegel, P. Waloschek

Fermi National Accelerator Laboratory, (USA)
Judy Jackson

GSI Darmstadt, (Germany)
G. Siegert

INFN, (Italy)
A. Pascolini

IHEP, Beijing, (China)
Qi Nading

JINR Dubna, (Russia)
B. Starchenko

KEK National Laboratory, (Japan)
A. Maki

Lawrence Berkeley Laboratory, (USA)
B. Feinberg

Los Alamos National Laboratory, (USA)
C. Hoffmann

NIKHEF Laboratory, (Netherlands)
Margriet van der Heijden

Novosibirsk Institute, (Russia)
S. Eidelman

Orsay Laboratory, (France)
Anne-Marie Lutz

PSI Laboratory, (Switzerland)
P.-R. Kettle

Rutherford Appleton Laboratory, (UK)
Jacky Hutchinson

Saclay Laboratory, (France)
Elisabeth Locci

IHEP, Serpukhov, (Russia)
Yu. Ryabov

Stanford Linear Accelerator Center, (USA)
M. Riordan

TRIUMF Laboratory, (Canada)
M. K. Craddock

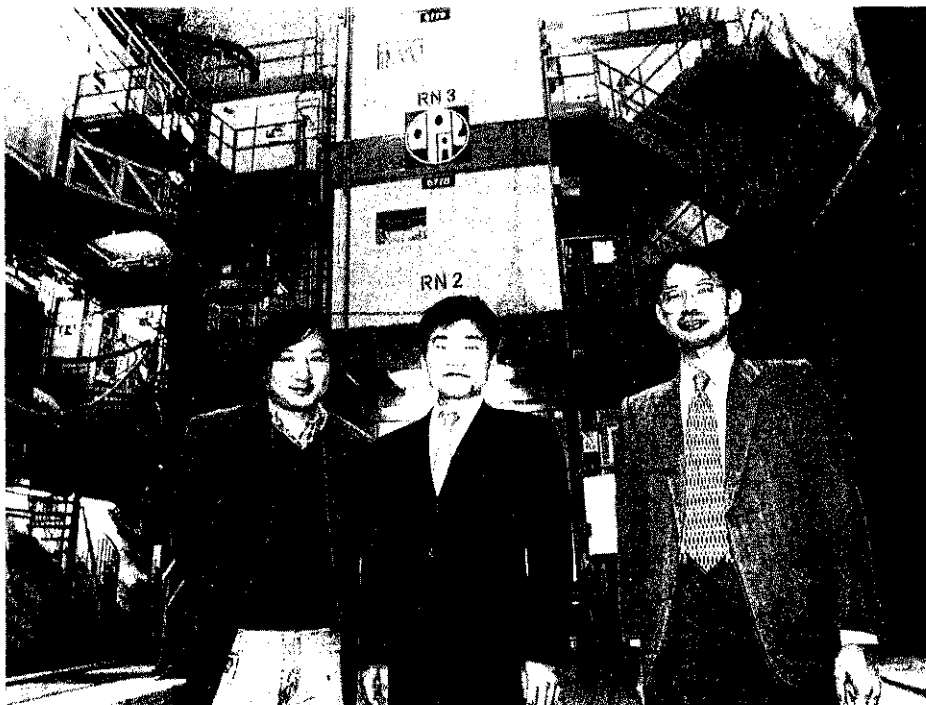

CERN Courier

In the most significant development for the CERN Courier since the decision to 'go international' in 1975, we are pleased to announce that the UK Institute of Physics Publishing, Bristol, will manage the journal.

Although we are justifiably proud of the reputation which the CERN Courier has achieved and the position it has established as a showcase for world particle physics, it has become increasingly clear that the business of handling a magazine with a total print run of 27,500 and worldwide distribution has outstripped what CERN can reasonably manage.

Now CERN, through Courier Editor Gordon Fraser, retains editorial control, with the vital support of a network of correspondents, while IOPP takes responsibility for production and development.

With IOPP's acknowledged journal and magazine reputation and its expertise in electronic publication, we look forward to exciting new developments which will consolidate the Courier's position as the international journal of particle physics. Its serious coverage of discoveries, timely news of developments and informed progress reports should bring advances in basic physics and increased understanding of the structure of the Universe to a wider audience.

1998 LEP flying start

A good omen for 1998 operations at CERN's LEP electron-positron collider when on 20 May, a 500 microamp beam of positrons was accelerated to a record energy of 96.5 GeV using 2.9 GV of radiofrequency. The conditions were stable with a lifetime of more than 20

Former CERN Director General Herwig Schopper (left) receives the 650-year Jubilee Medal of Prague's Charles University from Rector Karel Maly. Schopper's lecture "Universities and Large Research Centres - a Beneficial Symbiosis" at a conference on "The Role of the University at the Threshold of the 21st Century" used CERN as an example for such fruitful collaborations.



hours. LEP is now equipped with 256 superconducting niobium-sputtered copper cavities giving 2621 MV of power, 16 superconducting solid niobium cavities giving 136 MV, and 52 conventional copper ones giving 130 MV. With the niobium-copper cavities running extremely well, LEP is able to deliver a maximum kick to its circulating particles. Soon afterwards, LEP was colliding electrons and positrons for physics at a new high energy of 94.5 GeV per beam (collision energy 189 GeV) with good luminosities.

Yen for CERN

Japan's Ministry of Education, Sports, Science and Culture (Monbusho) has announced, subject to formal approval, a further contribution of 5 billion yen for the construction of CERN's LHC collider. In May 1995, Japan made a first contribution of 5 billion yen to the LHC, and the country became an official CERN Observer State in June

of that year. In December 1996, Japan announced a further contribution of 3.85 billion yen. The total LHC contribution from Japan now amounts to 13.85 billion yen (some \$100 million at current rates of exchange).

Cooperation Agreement between Mexico and CERN

The research programme of CERN's LHC continues to attract attracting scientists from all over the world. For a couple of years a group of Mexican physicists have been working in the ALICE project which is planning to study high-energy heavy ion collisions at LHC. Countries other than CERN Members States play an important role within the ALICE collaboration. Recently the Mexican funding agency for Science and Technology - Consejo Nacional de Ciencia y Tecnología (CONACyT) and CERN Director General Chris Llewellyn Smith signed a Cooperation Agreement. The

document was signed by Director General Carlos Bazdresch Parada on behalf of CONACyT.

Physics in space

On 12 June, the Space Shuttle Discovery returned to Earth after a 10-day mission carrying as primary payload the three-ton AMS Alpha Magnetic Spectrometer experiment. This 100-hour precursor study provided valuable experience before deploying AMS on the International Space Station Alpha, provisionally scheduled for 2003. This could reveal the first evidence for nuclear cosmic antimatter, a major step towards resolving a long-standing puzzle about the apparent absence of antimatter in a Universe created in a Big Bang which supposedly produced matter and antimatter in equal amounts.

AMS is the first large scale physics detector deployed in space and the project, with major contributions from NASA and from the US Department of Energy, traditional paymasters of US particle physics, brings a novel and significant symbiosis of space-borne and particle physics research. First news from AMS in the next issue.

On people

As Peter Zerwas of DESY ends his term as Chairman of CERN's LEP Experiments Committee, he is succeeded by Roger Cashmore of Oxford.

Following the appointment of Enzo Iarocci as Chairman of the Italian INFN (April, page 31), his place as Chairman of CERN's LHC Committee is taken by Jos Engelen of the Dutch NIKHEF laboratory.

Bernard D'Almagne of LAL, Orsay,

Gerhard Söhngen (left), Deputy to the DESY Director of Research, receives a honorary doctor's degree by Yerevan State University for his "scientific-organizational activities" from R. Martirosian, Rector of Yerevan State University.



retiring from his position as Chairman of CERN's SPS and PS Experiments Committee, becomes Deputy Director of the French Institute of Nuclear and Particle Physics (IN2P3). The new experiments committee Chairman is Kay Königsmann from Freiburg.

Inside CERN, Paris Spiccas takes over as LEP physics coordinator from Pippa Wells.

On April 2, Gerhard Söhngen, Deputy to the DESY Director of Research, was awarded a honorary doctor's degree by Yerevan State University for his "scientific-organizational activities". He became a coordinator of Armenian and German particle physicists when Armenia became an independent republic in 1991, actively promoting the exchange of scientists - giving Armenian physicists the possibility of participating in HERA experiments and students to regularly take part in the DESY summer students programme.

In particular he promoted a satellite connection linking Armenia and Germany, allowing Armenia to

participate in global information links and to maintain contacts around the world. He actively supported the introduction of new computer and information technologies in Armenia itself.

First the personal assistant of DESY Director General Willibald Jentschke for two years, then founder and head of the DESY public relations division from 1968 to 1975, G. Söhngen has been Deputy to the DESY Director of Research for the past 23 years.

Pomeranchuk Prize

The 20 May was the 85th anniversary of the birthday of outstanding scientist and founder of Moscow's Institute of Theoretical and Experimental Physics (ITEP) Theory Division I.Ya.Pomeranchuk (1913-1966). To mark the date, ITEP established the Pomeranchuk Prize in Theoretical Physics, awarded for outstanding achievements in all the fields to which I.Ya Pomeranchuk contributed. The prize, awarded to two candidates annually, is attributed

by a committee headed by ITEP Director Michael Danilov. (Nominations should be sent to pomeron@heron.itep.ru not later than February 1.) More detailed information from <http://face.itep.ru/pomeranchuk.html>

The 1998 Prize is awarded to A.I. Akhiezer (Kharkov, Ukraine) and to S. Drell (Stanford). The former (born 1911) is honoured for his outstanding pioneering contributions to quantum electrodynamics (QED), physics of neutrons and to condensed matter physics. He worked with I.Ya Pomeranchuk in Kharkov (1935-1937) on QED, and later, when Pomeranchuk moved to Moscow, on various aspects of neutron physics and of condensed matter physics (1944-1961). Akhiezer is also known worldwide through his book with V.B.Berestetski on QED.

The Prize is awarded to Sidney Drell for his outstanding contributions to the quantum theory of electrodynamic hadronic process and for the development of the beamstrahlung theory for future colliders. He is the author, with J.D.Bjorken, of the famous monograph "Relativistic quantum fields".

Albert Hofmann retires

Renowned accelerator expert and almost equally renowned personality Albert Hofmann recently retired from CERN.

After a PhD at ETH Zurich in 1964, he spent seven years at the Cambridge Electron Accelerator (CEA), that breeding ground of accelerator talent, before coming to CERN in 1973. His ten very productive years at the Intersecting Storage Rings (ISR), working on bunched beam and coasting beam instabilities, RF noise, Landau cavity,

FACULTY POSITION

The University of Tennessee

The Department of Physics and Astronomy of The University of Tennessee, Knoxville invites applications for a tenure-track position at the full professor level in experimental elementary particle physics to begin in the 1998-99 academic year. Candidates should have a strong interest and experience in detector design and construction, and experience with large collaborations such as those at SLAC, Fermilab, CERN, or KEK. Leadership experience in directing a research group is highly desirable, as is interest in non-accelerator based experiments (e.g. baryon instability or neutrino oscillations). Candidates must have a Ph.D. in physics or equivalent and extensive experience in a faculty or research position, and must demonstrate ability to teach effectively at the undergraduate and graduate levels and to conduct a vigorous research program. Applicants should send vitae and the names and addresses of three references to Dr. Lee L. Riedinger, Head; Department of Physics and Astronomy; The University of Tennessee; 401 Nielsen Physics Building; Knoxville, TN 37996-1200. Review of applications will begin July 1, 1998 and continue until the position is filled. **UTK is an EEO/AA Title VI/Title IX/Section 504/ADA Employer.**



UPPSALA UNIVERSITY

New Director for The Svedberg Laboratory, Uppsala University, Ref no 2661/98

The Svedberg Laboratory (TSL) is a Swedish national research facility for accelerator-based research, hosted by Uppsala University. TSL is located close to the center of Uppsala and has a well developed infrastructure for guest users. The laboratory provides a range of accelerated ion beams for Swedish and international scientists with approved projects and carries out research using its own resources. TSL runs two accelerators; one combined synchrotron and storage ring (CELSIUS), with electron cooling, and one $K = 200$ MeV cyclotron, isochronous of frequency-modulated. The highest beam energy is 1.36 GeV for protons accelerated in CELSIUS. For light heavy ions with a charge-to-mass ratio of 1/2 the corresponding energy is 470 MeV/nucleon.

Eight scientists form the laboratory research staff and approximately 50 people are employed in total. Some 50 research projects are in progress, performed by about 250 PhD scientists and 50 PhD students, with half the users coming from foreign countries. Examples of active fields of research are meson production processes, rare decays of mesons, intermediate energy heavy-ion physics, basic and applied neutron physics, materials science, radiation biology and biomedicine.

For further information about the university and the laboratory, contact the University Director, Johnny Andersson (tel. +46 18 471 3312, fax: +46 18 471 1640, e-mail: johnny.HYPERLINK mailto:andersson@uadm.uu.se andersson@uadm.uu.se) or the present Laboratory Director, Leif Nilsson (tel.: +46 18 471 3061, fax: +46 18 471 3833, e-mail: HYPERLINK mailto:nilsson@tsl.uu.se nilsson@tsl.uu.se), or consult the web-site of the laboratory at <http://www.tsl.uu.se/>.

The laboratory is now seeking a new Director, who will be appointed by the Board of Uppsala University for a period of three years, with the possible extension of another three-year period. The Director will be offered a permanent position at Uppsala University after a 3 + 3 year period as Director.

The Director, together with the Programme Advisory Committee and the Board of TSL, is responsible for the scientific and technical development of the laboratory. The Director is further responsible for the day-to-day management of the laboratory.

The Board of TSL appoints a Deputy Director, but the Director decides upon the division of work between him/herself and the Deputy Director. The appointee is expected to take part in the research activities at the laboratory.

Qualifications

Documented wide experience in nuclear or particle physics research or in a closely related research field at professional level. Proven experience of managing research teams at international or large national laboratories, preferably laboratories for accelerator-based research.

Other qualifications of significance for the position.

Knowledge of and experience in accelerator physics research is considered to be an asset.

Application

The salary will be negotiated.

There is no specific application form.

The applications, together with CV and other documents, to which the applicants wish to refer, should be sent to Uppsala University, Registrars Office, Box 256, S-751 05 Uppsala, Sweden, to arrive there no later than August 3, 1998. Faxed applications (fax no. + 46 18 471 20 00) must be followed by a mailed copy carrying a hand-written signature in ink.



DESY Fellowship Programme

DESY announces the **DESY Fellowship Programme** for young scientists in experimental particle physics to participate in the research mainly with the HERA collider experiments H1 and ZEUS or with the fixed target experiments HERA-B and HERMES. New fellows are selected twice a year in April and October. DESY fellowships in experimental particle physics are awarded for a duration of two years with the possibility for prolongation by one additional year.

The salary for the fellowship is determined according to tariffs applicable for public service work (BAT II a).

Interested persons, who have recently completed their Ph.D. and who should be younger than 32 years are invited to send their application including a resume and the usual documents (curriculum vitae, list of publications, copies of university degrees) until 30 of september or 31 of march of each year to

DESY
Personalabteilung
Notkestraße 85, D-22607 Hamburg

They should also arrange for three letters of reference to be sent until the same date to the address given above.

Handicapped applicants with equal qualifications will be preferred.

DESY encourages especially women to apply.

As DESY has laboratories at two sites in Hamburg and in Zeuthen near Berlin, applicants may indicate at which location they would prefer to work.

Nonconformist Albert Hofmann - at work in the LEP tunnel.



etc, appropriately included two years as Chairman of the Performance Committee for that record-breaking machine. After switching to LEP beam instrumentation, in 1983 he moved back to the US, this time to Stanford. In 1987 he was fortunately enticed back to CERN in time for a major role in the commissioning of LEP. After this success, Albert strove to push LEP performance and played a crucial part in its delicate energy calibration.



Manuel Aguilar Benitez de Lugo, Director of the Department of Fusion and Elementary Particles, CIEMAT, Madrid, receives the prestigious 1997 Science Prize of the Spanish CEOE Foundation for his contributions to the study of elementary particles and the development experimental high energy research in Spain from CEOE Foundation President Carlos Ferrer Salut.

A brilliant physicist and experimenter, having contributed to about 20 different machine projects all over the world, his insight can be impressive - it was Albert, with the late Gerry Fisher, who explained mysterious LEP effects as being due to Earth tides. Moreover he has always been willing to impart this wisdom to whoever asks.

Almost as much as his scientific contributions and generosity, his exaggerated modesty, infuriating optimism and mischievous humour have endeared him to all.

During the recent SysComms conference on Real-Time and Embedded Systems, held at CERN, Chris Parkman of CERN (right) receives the VMEbus Personality of the Year Award for his contributions towards the advancement of VMEbus in Europe from Ray Alderman of VITA, the VMEbus International Trade Association.

Meetings

The XXVII International Symposium on Multiparticle Dynamics, ISMD98, organized by the University of Athens will be held at the European Cultural Centre in Delphi, Greece, from September 6 - 11. The Symposium brings together theorists and experimentalists with broader interests. The Conference will cover: 1) Non-perturbative QCD in soft hadronic processes; 2) Interplay between soft and hard processes; 3) Hadronic final states in electron-positron and lepton-hadron collisions; 4) New developments in heavy ion collisions; 5) Fluctuations and correlations in high energy collisions; 6) Multiparticle dynamics in astroparticle physics. Secretary of ISMD98 is: Ms. Lia Kontraros, tel: +30-1-7257533, fax: +30-1-7295069. e-mail: ISMD98@atlas.uoa.gr Internet: <http://www.uoa.gr/congres/ismd98.htm>

Please take note of the change of date and chairman of the 4th Workshop on Small-x and Diffractive Physics; to be held at Fermilab, September 17-20, Andrew Brandt, Fermilab, and Alan White, Argonne, are Co-Chairs. More information from <http://www.hep.anl.gov/Theory/smxdf.html>



Frederick Lobkowitz

Frederick Lobkowitz of Rochester died on 3 February from complications following a heart attack. He was 65. An exceptionally versatile scientist, he participated in experiments at many accelerator laboratories, and introduced liquid argon calorimetry at Fermilab, where he and his collaborators constructed two large instruments for studying the radiative widths of mesons and direct photon production. His most recent contributions were to the D0 experiments at the Fermilab Tevatron, and to the liquid argon calorimeter being developed for the ATLAS detector at CERN's LHC.

Frederick Lobkowitz

CERN Courier contributions

The Editor welcomes contributions. These should be sent via electronic mail to cern.courier@cern.ch

Plain text (ASCII) is preferred. Illustrations should follow by mail (CERN Courier, 1211 Geneva 23, Switzerland).

Contributors, particularly conference organizers, contemplating lengthy efforts (more than about 500 words) should contact the Editor (by e-mail, or fax +41 22 782 1906) beforehand.

CRISTINA WIRTH: "Dessine-moi un drapeau"





RIKEN BNL Research Center

Brookhaven National
Laboratory

SCIENTIFIC STAFF POSITIONS

Experimental Spin Physics

A research center focusing on the physics program of the Relativistic Heavy Ion Collider (RHIC), hard QCD/spin physics, lattice QCD and relativistic heavy ion physics has been established by the Institute of Physical and Chemical Research, Japan (RIKEN) at Brookhaven National Laboratory. An experimental division on spin physics will be established this summer. The RHIC will be the first polarized proton collider, beginning in 2000, and the Center will play a major role in developing the RHIC spin program. RIKEN-BNL Fellow (up to a five-year appointment) and Research Associate (two-year appointment) positions will be offered for the fall of 1998. Members of the experimental division of the Center will have the opportunity to participate in the detector program at RHIC.

Scientists with appropriate backgrounds who are interested in applying should send a curriculum vitae and three letters of reference to Dr. T.D. Lee, Building 510A, Brookhaven National Laboratory, P.O. Box 5000, Upton, Long Island, NY 11973-5000, before July 15, 1998. BNL is an equal opportunity employer committed to workforce diversity.

BROOKHAVEN NATIONAL LABORATORY

on the frontier of science and technology

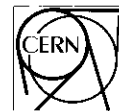

CERN

**European Laboratory for Particle
Physics**

CERN is the world's largest laboratory
for scientific research.
With 19 Member States,
it is used by elementary particle physics
researchers from all countries.

Visits on request
tel. 0041 22 767 8484

Microcosm exhibition,
Monday-Saturday from 9.00 to 17.00 hr,
entry free

Route de Meyrin (bus 9 CERN)

Les rêves relatés pourraient avoir subi la patine de l'inconscient - à la fois archéologue, homme grenouille et journaliste - un peu par hasard - devenir astronaute, biologiste puis interprète - jamais su que faire - la prédiction de devenir un artiste - pilote d'avion, danseuse, vétérinaire - tenté par les métiers d'ingénieur ou d'architecte - à la question de l'orientation, personne n'a hésité - rêvé d'être pianiste classique puis champion d'échecs, avant de vouloir être physicien théoricien - jardinier - peut-être pour ne pas décevoir mon père - inventé un métier, "ingénieur photographique": personne cherchant à comprendre des émulsions photographiques - pilote d'avion et conducteur de camion déchets - déjà intéressé par la vie académique - être acteur de théâtre - besoin de suivre un seul chemin - exactement le métier rêvé, mais la volonté de ne pas continuer dans ce milieu - être chirurgien - ils ne l'ont pas voulu et ils avaient raison - représenter un pays dans un sport quelconque - travailler avec des animaux - aujourd'hui la technique en horreur - d'autres intérêts: le dessin publicitaire, l'architecture, les bandes dessinées, la beauté de la nature et aussi la mécanique - pas de conception d'un futur métier - être astronaute - devenir chimiste et, ensuite, peintre ou musicien - une longue succession de circonstances - infirmière ou assistante sociale - pilote d'avion, boulanger, instituteur - voyageur dans l'espace ou vendeur dans le magasin de poissons paternel - pas de souvenir d'une future profession - pilote de Formule 1 et gagner le Championnat du monde - poussé dans cette direction - paysan - des phases policier et pompier - passé par dessinateur, pilote, puis guide de montagne - fasciné par les locomotives - pas sûr d'avoir rêvé précisément d'un métier - devenir médecin et pilote de ligne - archéologue et après, physicienne - pas vraiment à faire toute la vie - être écrivain ou cinéaste - le souvenir des histoires qu'un oncle racontait avec brio sur les physiciens du Cern.

CLAUDIA GISLER

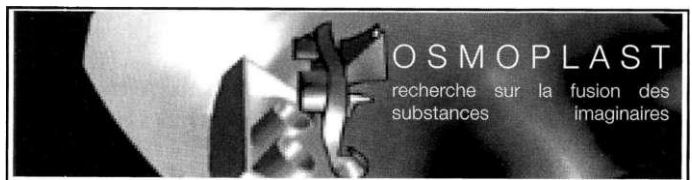

Le laboratoire de recherche expérimentale, prochainement installé dans la cabane No 6410, parking Newton du CERN, s'occupe de l'observation de nouvelles particules réalisées en images de synthèse.

Grâce à une animation dynamique et par ajustement de paramètres, les particules simulées rentrent en collision et se transforment, une étude de différentes matières aléatoires est en cours.

Les programmes utilisés décèlent également les déplacements des chercheurs autour de la machine et ces mouvements déterminent la configuration des images.

Nous recherchons un programmeur intéressé pour participer à cette recherche.

Le candidat doit connaître les logiciels de détection des particules et de simulation de leurs mouvements. Une expérience dans le domaine des matières procédurales est vivement souhaitée.

Cette collaboration est l'occasion de créer un objet hybride entre art et science.

Pour participation et plus d'informations contacter:

Elodie Formaris
tel: 021 702 95 52
021 702 95 59
fax: 059 450 41 01 94
email: elodie_formaris@hotmail.com
elodie.formaris@ecal.vd.ch

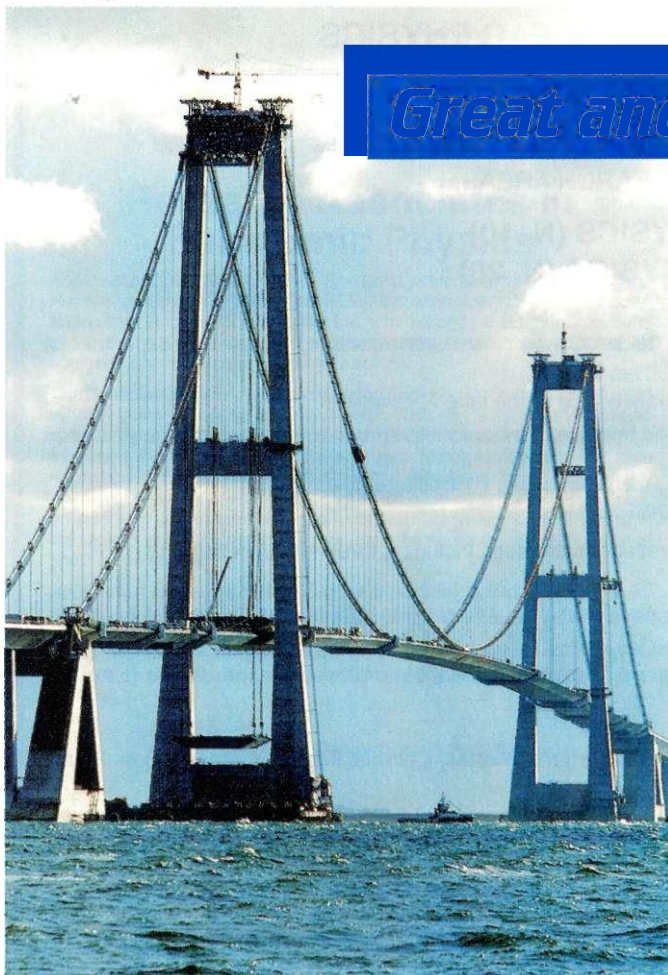

Great and reliable engineering

With the Model 889 in the SYSTEM 8800 power converter program we are offering our customers a new generation of high performance power converters incorporating primary soft switching technology with IGBT's operating at 20 kHz. With the Model 889 we are introducing a high current modular system to meet the increasing demand for powering superconducting loads with currents ranging from 4 to 32 kA.

- Basic module can deliver 4kA/24kW
- Paralleling of modules up to 32kA
- Full bridge primary converter
- Excellent current stability
- Short circuit and open circuit operation
- All power components are water cooled
- Very high efficiency - typically 85 %

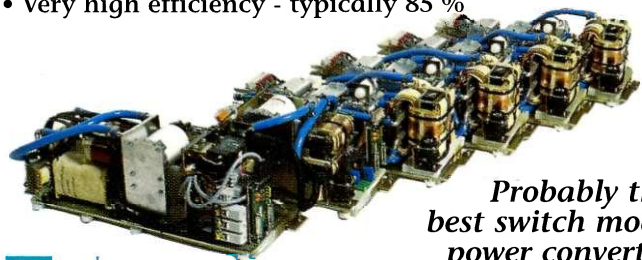

Probably the best switch mode power converter technology you can buy...



Danfysik A/S · DK-4040 Jyllinge · Denmark
Tel. international: +45 46 78 81 50 · Fax: +45 46 73 15 51 · e-mail: dfysik@inet.uni-c.dk
In USA: GMW Associates · Tel. (650) 802-8292 · Fax (650) 802-8298
In India: Transact India Corp. · Tel.: (22) 285-5261 · Fax: (22) 285-2326

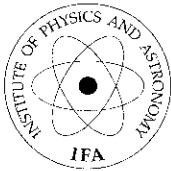

**Institute of Physics and Astronomy
Aarhus University**

Post Doctoral Research Position

The Centre for CERN related Atomic and Nuclear Physics under the Danish Natural Science Research Council invites applications for a post doc position in experimental atomic physics. The position is open from September 1, 1998 for a 2 year period with the possibility of extension.

The successful applicant shall participate in an experimental program which aims to investigate the interaction between slow antiprotons and atoms. Phenomena such as energy loss, ionization and channelling will be studied. The program has as one long term goal the production and characterization of antihydrogen. The experiments will be designed and tested at Institute of Physics and Astronomy, Aarhus University, and will be carried out at the AD facility at CERN (Geneva) under the ASACUSA and ATHENA collaborations. The applicant shall work closely together with the members of the former PS194 and NA43 collaborations.

Applicants with experience in atomic collision experiments and/or experimental work at CERN will be preferred.

A PhD degree in experimental physics (or the equivalent) obtained within the past five years is a recommended pre-requisite. The salary depends on seniority as agreed between the Danish Ministry of Finance and the Confederation of Professional Unions.

Applications should include a curriculum vitae giving evidence on which the evaluation of the applicant's scientific qualifications can be based, a complete list of publications with an indication of those which the applicant selects as the most relevant for the application. The applicant must, upon request, submit further material required by the selection committee in its evaluation.

Applications (4 copies) including two letters of reference should be addressed to Faculty of Science, University of Aarhus, Ny Munkegade, Building 520, DK-8000 Aarhus C, Denmark, and marked 212/5-127. The deadline for the receipt of all application material is August 3, 1998.

For further information, contact Dr. Helge Knudsen, Institute of Physics and Astronomy, Aarhus University, DK-8000 Aarhus C, Denmark. Phone: (+45) 8942 3607, E-mail: hk@dfi.aau.dk. Information about the Institute can also be found at <http://www.dfi.aau.dk>



**Professor Position in
Theoretical Particle Physics**

The Physics Department at Technical University Munich invites applications for a professor position which is at the C3 level and limited for five years. We are seeking candidates working in theoretical particle physics in connection with the special research project astro-particle physics (Sonderforschungsbereich Astroteilchenphysik - SFB 375).

The candidate has to fulfil the usual teaching obligations and is therefore expected to show a high grade of teaching ability.

The Technical University Munich encourages women to apply. Disabled candidates of equal qualifications are favoured.

Applications including a curriculum vitae, a list of publications, a short summary of research interests, selected reprints and information about teaching experience should be sent **before July 20, 1998** to

*Dekan der Fakultät für Physik
Technische Universität München
James Franck Str.
D-85747 Garching, Germany*

NATIONAL INSTITUTE FOR NUCLEAR PHYSICS

I . N . F . N .

**POST-DOCTORAL FELLOWSHIPS FOR NON ITALIAN CITIZENS
IN THE FOLLOWING RESEARCH AREAS:**

**THEORETICAL PHYSICS (N. 10)
EXPERIMENTAL PHYSICS (N. 20)**

The I.N.F.N. Fellowship Programme 1998-99 offers thirty positions for non Italian citizens for research activity in theoretical or experimental physics.

Fellowships are intended for young post-graduates not more than 38 years of age at the time of deadline.

Each fellowship is granted for one year (which may start during the period from September to November 1999), and may be extended for a second year.

The annual gross salary is 36,000,000 Italian Lire, plus travel expenses for round trip transportation from the home fellows to the I.N.F.N. Section or Laboratory. Lunch tickets are provided for work days.

Candidates should submit an application form and a statement of their research interests, including three letters of reference.

Applications should be sent to I.N.F.N. not later than *October 15, 1998*.

Candidates will be informed by the end of March 1999 about the decisions taken by I.N.F.N.'s committee.

The successful applicants may carry out their research activity in Italy, at any of the following Laboratories and Sections of I.N.F.N.: National Laboratories of Frascati (Rome), National Laboratories of Legnaro (Padua), National Laboratories of Gran Sasso (L'Aquila) and Southern National Laboratory (Catania).

I.N.F.N. Sections in the Universities of:

Turin, Milan, Padua, Genoa, Bologna, Pisa, Rome 'La Sapienza', Rome 'Tor Vergata', Naples, Catania, Trieste, Florence, Bari, Pavia, Perugia, Ferrara, Cagliari, Lecce and Rome 'Tre'.

Informations, requests for application forms, and applications should be addressed to Personnel Office - Fellowship Service, National Institute of Nuclear Physics (I.N.F.N.) - Post Box 56 - 00044 Frascati (Rome) Italy.

**NATIONAL INSTITUTE FOR NUCLEAR PHYSICS
THE PRESIDENT
(Prof. Luciano Maiani)**

Post Doctoral Positions in Experimental Particle Physics

The Fermi National Accelerator Laboratory (Fermilab) has openings for post doctoral research associates in experimental particle physics. The Fermilab research program includes experiments with the 2 TeV proton - anti-proton collider and 800 GeV fixed target experiments. There are several positions for recent Ph.D.s in the CDF and D-Zero collider efforts which have major detector upgrades in progress and are scheduled to begin data taking in early 2000. There are also some limited opportunities to join fixed target experiments where analysis from the data taking in the run completed in September, 1997 is now in progress. Further fixed target running is being planned for 1999.

Successful candidates are offered their choice among interested Fermilab experiments which have openings at the time of the offer. Appointments are normally for three years with one year renewals possible thereafter. Every effort will be made to keep a Fermilab RA until he or she has the opportunity to reach physics results from his or her experiment.

Applications should include a curriculum vita, publication list and the names of three references. Applications and requests for information should be directed to **Dr. Michael Albrow, Head - Experimental Physics Projects, [Albrow@fnal.gov], Fermi National Accelerator Laboratory, M.S. 122, P.O. Box 500, Batavia, IL 60510-0500.** EOE M/F/D/V.



CLAS Data Acquisition System Physicist (Position #PR2143)

The Thomas Jefferson National Accelerator Facility invites applications for the position of a CLAS Data Acquisition System Physicist in the Hall B Group of the Physics Division. The CLAS detector in Hall B at Jefferson Lab is instrumented with wire chambers, scintillation counters, and gas Cerenkov detectors. The data acquisition and control of the detector components is accomplished with a cluster of SUN Unix processors in the control room and with about 30 distributed controllers/processors in the hall connected by Ethernet. The Hall B Group is looking for an individual who will be responsible for data acquisition related hardware and software. The data acquisition framework is provided by the in-house CODA group, and CLAS specific software must be added to match the detector components. The successful candidate must have experience with digitizing and control electronics in Fastbus, VME, and Camac crates as well as with embedded processors, workstations, and multi-processor machines operating as Unix or Unix-like platforms. It is required that the incumbent be able to carry a project through all phases of design, implementation, and testing, and be very familiar with testing/debugging hardware, and communicate well with the CLAS on-line group, the CODA group and representatives of the various detector components.

A Ph.D. in Experimental Physics is required, with at least three years experience with hardware implementation and software development for complex experimental physics detectors. A proven track record of significant contributions to on-line software and hardware projects; in particular, expertise with Fastbus, VME, and Camac protocols, with time and pulse height digitizing units as well as with real-time event-driven processing and communication among real-time processes. A good working knowledge of UNIX, Fortran and C as well as several scripting languages, such as Perl, Tel/Tk, csh, etc. Knowledge of C++ and experience with HTML documents desirable. Applicants should submit a CV, including the names of at least three references, to:

**Jefferson Lab
Attn: Employment Manager
Mail Stop 28D
12000 Jefferson Ave.
Newport News, VA 23606, U.S.A.**

Please specify Position number PR2143 and job title when applying.

Jefferson Lab is an Affirmative Action/Equal Opportunity Employer.



TRIUMF

MESON RESEARCH FACILITY
University of Alberta
Simon Fraser University
University of Victoria
University of British Columbia

Research Associates in Subatomic Physics

Applications are invited for two Research Associate positions with the Hermes group at TRIUMF. The HERMES experiment, which has been taking data since 1995, measures the spin dependent structure functions of the proton and the neutron using deep inelastic scattering of polarized positrons from polarized gas targets at HERA.

The Canadian group is responsible for the transition radiation detector used to distinguish between positrons and hadrons, and for the particle identification algorithms used in the analysis of the data. We are currently focusing our physics analysis efforts on the following topics: semi-inclusive hadron asymmetries and polarized quark distributions; flavour asymmetry of the quark sea; quark fragmentation functions; vector meson production; and ratios of unpolarized structure functions. The group is also involved in the design and construction of new drift chambers used in the study of charm productions.

Applicants must have a PhD in nuclear or particle physics. The successful candidates will spend a third of their time on hardware support or technical analysis, the rest on physics analysis. They will be expected to spend a significant amount of time at DESY in Hamburg, Germany. Salary is competitive and based on experience. Please forward your C.V. and three referees to:

**TRIUMF
Human Resources Department (Comp. #725-515)
4004 Wesbrook Mall
Vancouver, B.C.
Canada V6T 2A3**

Applications will be accepted until the position is filled. For more information contact Dr. M. Vetterli (vetm@triumf.ca).

We offer equal employment opportunities to qualified male and female applicants. In accordance with Canadian immigration requirements, this advertisement is directed first to Canadian citizens and permanent residents.

science serving society

Lead Cryogenics Technician

As a member of the Accelerator Physics and Engineering Group in the LANSCE Division, you will assume a technical leadership role in the design, fabrication, procurement, assembly, and testing of cryostats for superconducting linear accelerators for the Accelerator Production of Tritium Project and other Division projects. Interact with linac and beam transport physicists, cryogenics, mechanical and electrical engineers, mechanical designers, fabrication and test technicians to define technical and design requirements, plan the fabrication/assembly/test of cryostats. Create technical specifications for in-house and subcontract development, and provide training and technical direction. Applicants not meeting all requirements may be considered at a lower level.

Required Skills, Knowledge, Abilities:

15+ years experience in the manufacture, assembly, test and operation of beamline cryostats, superconducting magnets, and/or other cryogenics/superconducting components. A demonstrated understanding must include cryogenics refrigeration systems, vacuum technology, compressed gas (high purity) systems, and leak detection systems. Knowledge of cryostat fabrication and assembly techniques including instrumentation sensor installation. Progressive responsibility including supervision of technicians and work scheduling. Expertise in writing technical specifications and procedures.

Desired Skills, Knowledge, Abilities:

Experience with blueprints including ANSI Y14.5M dimensioning and tolerancing; machine tools and welding equipment; troubleshooting and repair of cryogenics refrigeration systems. Understanding of basic control functions is a plus.

Education, Training, or Licensing:

Associate of Science Degree in Mechanical Design or equivalent combination of education and experience.

Ability to obtain a DOE Q-clearance, which normally requires U.S. citizenship, is required. Applicants will be subject to a Federal background investigation and must meet eligibility requirements for access to classified matter.

For consideration, please send your resume referencing "CERN 983597" to: jobs@lanl.gov (no attachments, please) or mail to: Human Resources Division, Los Alamos National Laboratory, "CERN 983597," Mail Stop P286, Los Alamos, New Mexico 87545.

Los Alamos
NATIONAL LABORATORY



www.lanl.gov

EOE

FEEL OF COMPACT!

Here is a full-scale fold-out drawing to show you just how small and compact our HPD (Hybrid Photo Detector) actually is. Try it yourself! Make this model with your own hands and get a "feel" for how small this device really is!

52

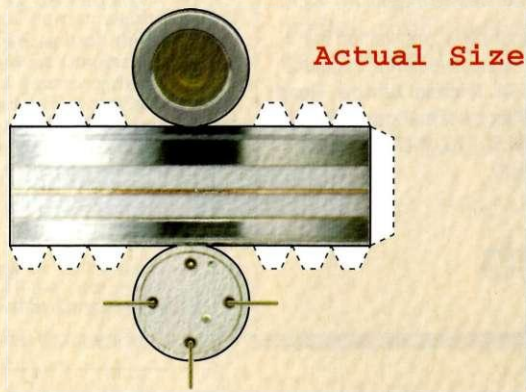

R7110U-07 Typical Characteristics

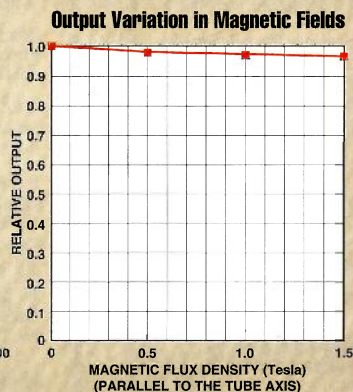
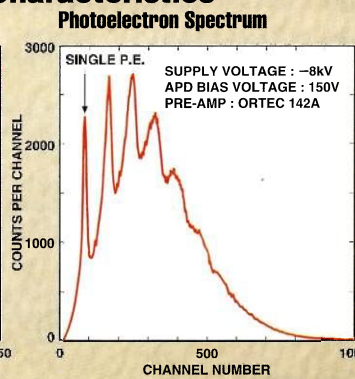
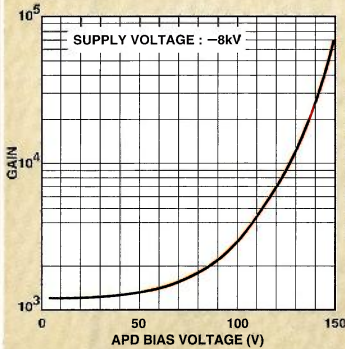

COMPACT HPD

R7110U-07 : Si-Avalanche Diode Target Type
R7100U-07 : Si-Diode Target Type

Spectral Response : 160 to 850 nm
Effective Area : 8 mm Dia.
Supply Voltage : 8000 V Max.
Weight : 13.8 g



HAMAMATSU PHOTONICS K.K., Electron Tube Center <http://www.hamamatsu.com>
314-5 Shimokanzo, Toyooka-village, Iwata-gun, Shizuoka-ken, 438-0193 Japan. TEL:81-539-62-5248 FAX:81-539-62-2205 TLX:4289-625

United Kingdom: Hamamatsu Photonics UK Limited. TEL:(44)181-367-3560 FAX:(44)181-367-6384
North Europe: Hamamatsu Photonics Norden AB. TEL:(46)8-703-29-50 FAX:(46)8-750-58-95
Italy: Hamamatsu Photonics Italia S.R.L. TEL:(39) 2-935 81 733 FAX:(39) 2-935 81 741

HAMAMATSU

U.S.A.: Hamamatsu Corporation. TEL:(1)908-231-0960 FAX:(1)908-231-1218
Germany: Hamamatsu Photonics Deutschland GmbH. TEL:(49)8152-3750 FAX:(49)8152-2658
France: Hamamatsu Photonics France S.A.R.L. TEL:(33) 1 69 53 71 00 FAX:(33) 1 69 53 71 10
Switzerland: CERN Liaison Office TEL:(41)31/879 70 70 FAX:(41)31/879 18 74